GUIDELINES FOR SPECIMEN TRANSPORT

**DEPARTMENT OF TRANSPORTATION
INTERNATIONAL AIR TRANSPORT ASSOCIATION
INTERNATIONAL CIVIL AVIATION ORGANIZATION
UNITED STATES POSTAL SERVICE**

Regulatory Agencies

Department of Transportation (DOT): 49 CFR

- Air
- Ground
- Water

International Air Transport Association (IATA)/

International Civil Aviation Organization (ICAO)

- IATA Member airlines, including FedEx and UPS

US Postal Services (USPS)

- Air mail (Category A infectious substances not allowed.)
- Parcel Post (Division 6.2 Materials not allowed.)

Category A Infectious Substances

Individuals who affect the transport of **Category A infectious substances** (including the documentation, packaging, and shipping) must have documentation of the required Department of Transportation (DOT) trainings as well as the required emergency response information available for the infectious agent in transport.

Category A infectious substances are defined as infectious substances transported in a form that when exposure occurs is capable of causing permanent disability or life threatening or fatal disease in otherwise healthy humans or animals. A list of indicative agents for Category A classification is provided below. This list is non-inclusive, and may not contain new or emerging pathogens.

Category A agents (Not all inclusive)

<i>Bacillus anthracis (cultures only)</i>	<i>Human immunodeficiency virus (cultures only)</i>
<i>Brucella abortus (cultures only)</i>	<i>Japanese Encephalitis virus (cultures only)</i>
<i>Brucella melitensis (cultures only)</i>	<i>Junin virus</i>
<i>Brucella suis (cultures only)</i>	<i>Kyasanur Forest disease virus</i>
<i>Burkholderia mallei – Pseudomonas mallei –</i>	<i>Lassa virus</i>
<i>Glanders (cultures only)</i>	<i>Machupo virus</i>
<i>Burkholderia pseudomallei – Pseudomonas</i>	<i>Marburg virus</i>
<i>pseudomallei (cultures only)</i>	<i>Monkeypox virus</i>
<i>Chlamydia psittaci – avian strains (cultures only)</i>	<i>Mycobacterium tuberculosis (cultures only)</i>
<i>Clostridium botulinum (cultures only)</i>	<i>Nipah virus</i>
<i>Coccidioides immitis (cultures only)</i>	<i>Omsk hemorrhagic fever virus</i>
<i>Coxiella burnetii (cultures only)</i>	<i>Polio virus (cultures only)</i>
<i>Crimean-Congo hemorrhagic fever virus</i>	
<i>Dengue virus (cultures only)</i>	<i>Rabies virus (cultures only)</i>
<i>Eastern equine encephalitis virus (cultures only)</i>	<i>Rickettsia prowazekii (cultures only)</i>
<i>Escherichia coli, verotoxigenic (cultures only)</i>	<i>Rickettsia rickettsii (cultures only)</i>
<i>Ebola virus</i>	<i>Rift Valley fever virus (cultures only)</i>
<i>Flexal virus</i>	<i>Russian spring-summer encephalitis virus (cultures only)</i>
<i>Francisella tularensis (cultures only)</i>	<i>Sabia virus</i>
<i>Guanarito virus</i>	<i>Shigella dysenteriae type 1 (cultures only)</i>
<i>Hantaan virus</i>	

<i>Hantavirus causing hemorrhagic fever with renal Syndrome</i>	<i>Tick-borne encephalitis virus (cultures only)</i>
<i>Hendra virus</i>	<i>Variola virus</i>
<i>Hepatitis B virus (cultures only)</i>	<i>Venezuelan equine encephalitis virus (cultures only)</i>
<i>Herpes B virus (cultures only)</i>	<i>West Nile virus (cultures only)</i>
<i>Highly pathogenic avian influenza virus (cultures only)</i>	<i>Yellow fever virus (cultures only)</i>
	<i>Yersinia pestis (cultures only)</i>

UN2900 Infectious substance, affecting animals

African swine fever virus (cultures only)
Avian paramyxovirus Type 1 – Velogenic
Classical swine fever virus (cultures only)
Foot and mouth disease virus (cultures only)
Goatpox virus (cultures only)
Lumpy skin disease virus (cultures only)
Mycoplasma mycoides – Contagious bovine pleuropneumonia (cultures only)
Peste des petits ruminants virus (cultures only)
Rinderpest virus (cultures only)
Sheep-pox virus (cultures only)
Swine vesicular disease virus (cultures only)
Vesicular stomatitis virus (Note: UN 2814 on DOT list)

Required Packaging and Shipping Trainings

Category A Infectious Substances & Dry Ice Certification Requirements

Individual(s) who affect the transport of **Category A infectious substances** or those who affect the transport of >5.5 lbs. per package of **Dry Ice by air** require certification to include the following:

- 1: Packaging and Shipping Infectious Substances Training & Test Documentation (as applicable to job function)
 - General Awareness/Familiarization Training
 - Function-specific Training
 - Emergency Response Information Training
- 2: Bloodborne Pathogen Safety Training & Test Documentation
- 3: Security Awareness training & Test Documentation Security awareness Training & Test (Ex. DOT Security Requirements Training Module 7
REGISTER: <http://dothazmat.vividlms.com/>)

****Note:** Entities that possess Select Agents must have facility-specific Security training.

Category B Infectious Substances

Individual(s) who affect the transport of **Category B infectious substances** are required to know and follow the Category B packaging instructions and have agent emergency response information available while materials are in transport during business hours. There is no additional requirement for formal training/testing for Category B shipments (except for CAP-accredited entities). IATA guidance suggests that you are familiar with regulations and that you understand classification.

Category B Infectious substances are defined as infectious substances transported in a form that when exposure occurs is NOT capable of causing permanent disability or life threatening or fatal disease in otherwise healthy humans or animals. Category B specimens can include both patient specimens and cultures.

General Notes:

- Recurrent Packaging and Shipping training is required every 3 years by DOT.
- US Postal Service (USPS) regulations align with IATA guidance.
 - Note: USPS will **not** accept Category A infectious substances.
- Federal Express (FedEx) and United Parcel Service (UPS) commercial entities follow IATA guidance.
- FedEx and United Parcel Service (UPS) will accept Category A infectious substances.
 - As of 2010 FedEx requires use of error-editing software such as FedEx Ship Manager software when completing Shipper's Declaration Forms. Contact FedEx at 800-GOFEDEX, 800.463.2774 (Ship Manager Support), or 800.339.3339, prompt 81 (Dangerous Goods) for details.
 - UPS requires that their most current version of shipping software is downloaded and that a UPS Dangerous Goods Agreement and UPS Customer Qualification Checklist are completed and submitted to UPS prior to shipping Category A infectious substances.

Packaging and Shipping of infectious substances (Division 6.2 materials) is dependent on a few important steps:

1. **Identification-** Identify that what you are attempting to send is a hazardous substance. An infectious substance is defined as a material known or reasonably expected to contain a pathogen that is likely to cause disease in humans or animals. It is also important to identify any additional hazardous materials that may be included with your sample/package such as dry ice.
2. **Classification-** If it has been determined that this is an infectious substance, the next step is classifying the hazard. There are two main categories within this classification: Category A and Category B.

3. **Method of transport**-The next step is to identify the method of transport. This will determine the regulating agency and governing regulations. If you are sending it through the mail, the USPS Publication 52 (formerly the Domestic Mail Manual) 39 CFR regulations apply, surface transportation/rail are regulated by Department of Transportation, Hazardous Material Regulations (HMR) 49 CFR, Parts 171-177 and air transport entities follow DOT regulations and the International Civil Aviation Organization/International Air Transport Association ICAO/IATA Dangerous Goods guidance. It is important to note that the United States Postal Service (USPS) will not accept Category A infectious substances.
- 4a. **Package, Mark, and Label** -Example of Packing and Marking for **Category A** infectious substances (Category A packaging must be UN-certified and tested by the manufacturer.)

Infectious Substances

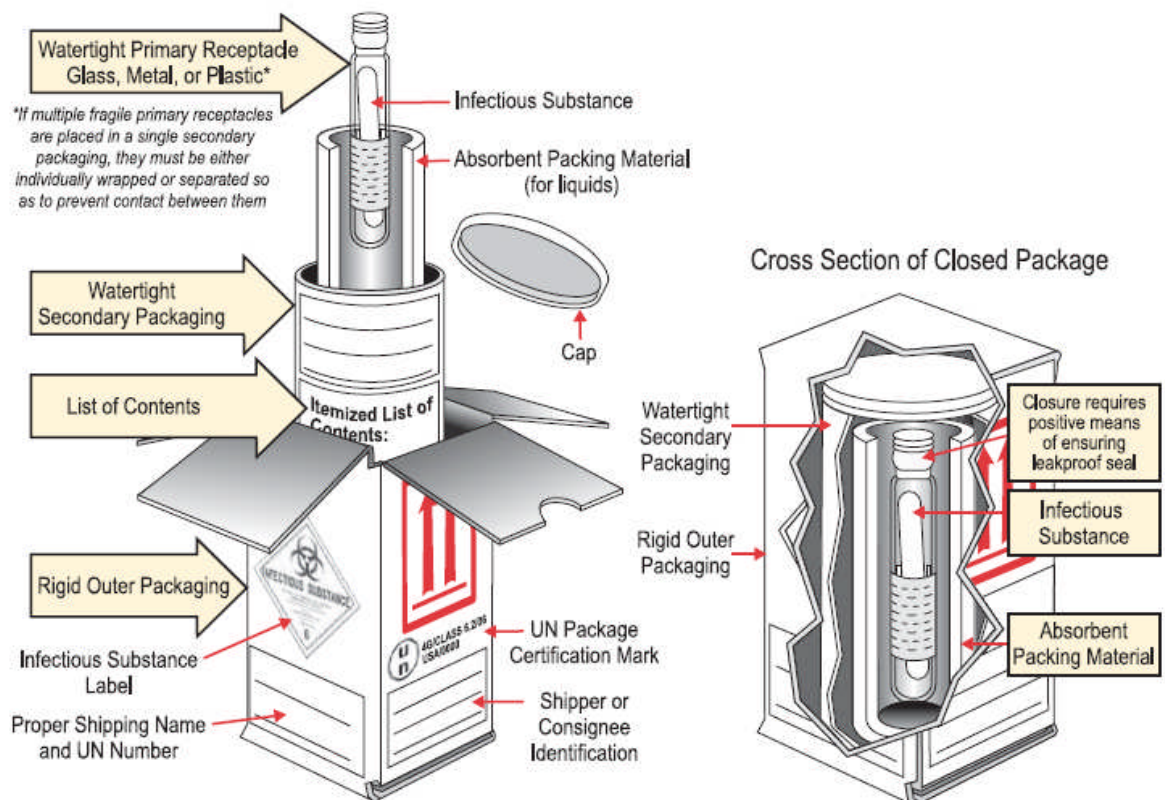

- Note 1:** The smallest external dimension of the outer packaging must not be less than 100 mm (3.9 inches)
- Note 2:** The primary receptacle or the secondary packaging must be capable of withstanding without leakage an internal pressure producing a pressure differential of not less than 95 kPa
- Note 3:** Follow package manufacturer's closure instructions

4b. **Package, Mark, and Label** -Example of Packing and Marking for **Category B** infectious substances

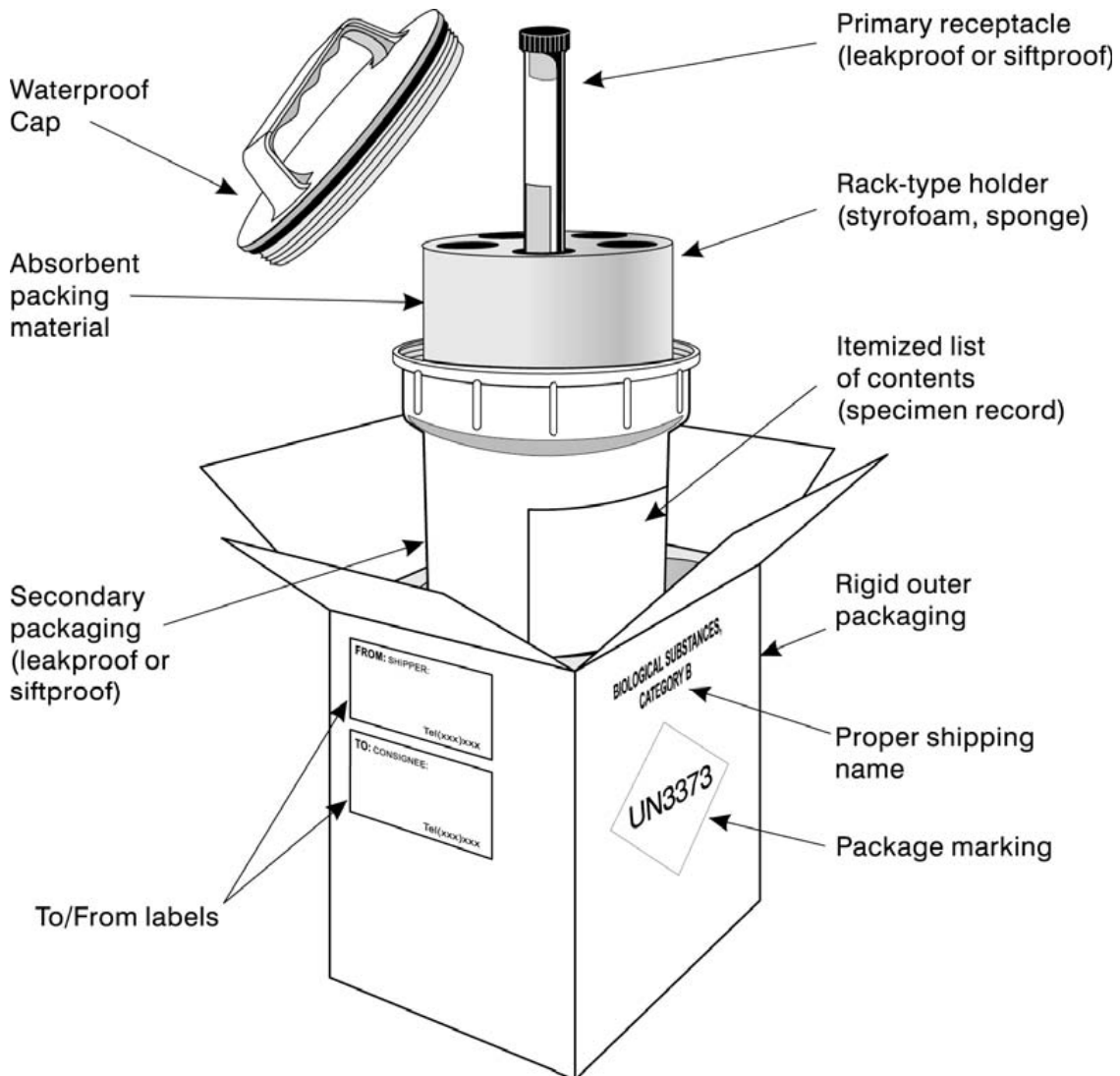

At least one surface of the outer packaging must have a minimum dimension of 100 mm x 100 mm;

The outer packaging must be of adequate strength for its capacity, mass and intended use.

4c. **Package, mark, and label** -Example of packing and marking for **Exempt** specimens.

This category includes human or animal specimens that are being transported for routine testing not related to an infectious disease. These specimens include those in which there is a low probability of the sample being infectious as determined through professional judgment taking into consideration known medical history, symptoms and source information, human or animal, and local endemic local condition.

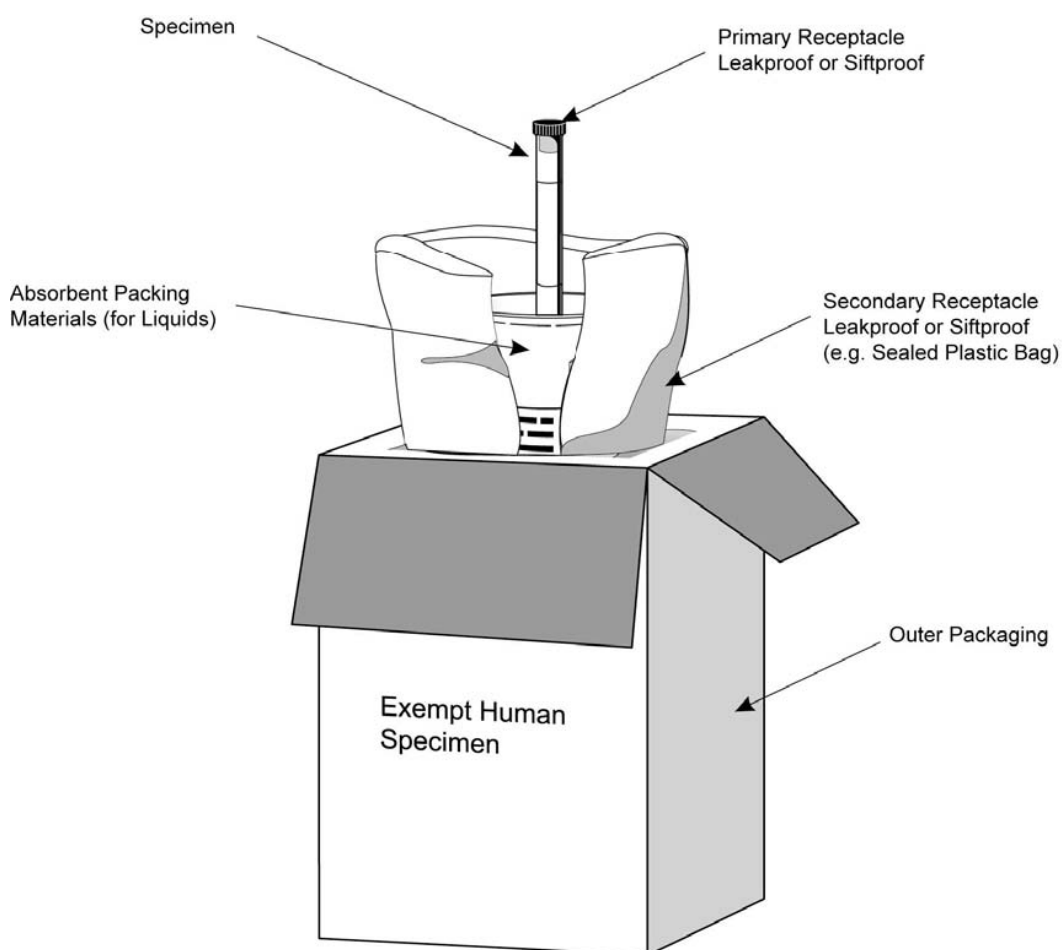

At least one surface of the outer packaging must have a minimum dimension of 100 mm x 100 mm;

The outer packaging must be of adequate strength for its capacity, mass and intended use.

5. **Documentation** -The documentation required is dependent on the classification and the method of shipping. Both DOT and IATA require that a shipper's declaration form be completed when shipping Category A agents. The IATA dangerous goods form is usually a red candy-stripped form that must include shipper's and consignee's name and address and a 24/7 emergency phone number. This form must also contain the proper shipping name and UN number, the quantity, the packaging instructions followed and a detailed description of the contents and packaging. The form's declaration statement must also be signed. It is important to note that anyone packaging and shipping Category A agents **must** have documentation of appropriate training certification. For DOT, Category A infectious substances may be documented on the IATA form or on a separate form generated that contains the information in Section 172.202 of 49 CFR. Category B shipments being sent by air require an airway bill or appropriate printed label. Please note that pursuant to the IATA guidance, the information to be included on the Air Waybill includes the proper shipping name & UN identification number, the number of packages, and the emergency contact information (if not included on the package). Dry ice information needs to also be included on the Airway bill if included in the package.

6. **Guidance**-The following sections provide additional guidance for each of the regulating agencies and their respective regulations.

United States Postal Service Division 6.2 Infectious Substance (USPS Publication 52)

Category A Infectious Substances (USPS)

Under the USPS Publication 52 regulations Category A Infectious substances cannot be mailed.

Category B Infectious Substances (USPS)

Proper Shipping Name and ID Number

All Category B infectious substances must meet the triple packaging requirements of USPS Publication 52, Packaging Instruction 6C, DOT 49 CFR, Section 173.199 and be sent as Express Mail, Priority Mail, or First-Class Mail service. The proper shipping name Category B infectious substances is Biological substance, Category B and packages must be marked with the UN3373 identification number.

Category B Required Packaging

Primary Receptacle

- The specimen material must be packaged in a durable and securely sealed primary receptacle.
- If the primary container contains a solid it must be sift proof.
- The volume in a single primary receptacle may not exceed 1 liter.
- Two or more primary receptacles whose total volume does not exceed 4L or 4kg may be enclosed in a secondary container.

Absorbent and Cushioning Material

Absorbent material must surround the primary receptacle or be otherwise configured to take up all of the liquid content in the primary receptacle in case of leakage. Sufficient cushioning material to withstand shock and pressure changes must surround the primary receptacle.

Secondary Packaging

- The primary receptacle and the absorbent cushioning must be enclosed in a secondary packaging that has a leak proof barrier capable of preventing the failure of the secondary packaging should there be leakage from the primary receptacle.
- Either the secondary or primary container must be capable of withstanding an internal pressure differential of not less than 95kPa pressure without leakage.
- The secondary packaging must be marked with the international biohazard symbol.

Category B Infectious Substances (USPS) cont'd.

Outer Packaging (referenced from USPS Publication 52, Packaging Instruction 6C, DOT 49 CFR 173.199)

- The outer package must be sturdy and rigid so that the entire package is able to withstand normal transportation and handling without release of hazardous material into the environment.
- The packaging must be capable of successfully passing the drop tests of at least 1.2 meters (3.9 feet) without leakage from the primary receptacle.
- At least one surface of the outer packaging must have a minimum dimension of 100 mm by 100 mm (3.9 inches).

Markings

- The address side of the mail piece must be clearly marked Biological Substance Category B and must be marked with the correct UN number (UN3373).
- Orientation arrows may be used but are not required.
- A name and phone number of a responsible person familiar with the contents and having emergency response information must be included on the outside of the package.

Exempt human/animal specimens (USPS)

This category includes human or animal specimen that are being transported for routine testing not related to an infectious disease. These specimens include those in which there is a low probability of the sample being infectious. These samples are not subject to hazardous material regulations but must meet packaging requirements found in USPS Publication 52, Packaging Instruction 6H.

Exempt Specimen Required packaging

Primary Receptacle

- The specimen material must be packaged in a durable and securely sealed primary receptacle. If the primary container contains a solid it must be sift proof.
- The volume in a single primary receptacle may not exceed 500mL or 500g if a solid.
- Two or more primary receptacles whose total volume does not exceed 500mL or 500g may be enclosed in a secondary container.

Absorbent and Cushioning Material

Absorbent material must surround the primary receptacle or be otherwise configured to take up all of the liquid content in the primary receptacle in case of leakage. Sufficient cushioning material to withstand shock and pressure changes must surround the primary receptacle.

Exempt human/animal specimens (USPS) cont'd.

Secondary Packaging

- The primary receptacle and the absorbent cushioning must be enclosed in a secondary packaging that has a leak proof barrier capable of preventing the failure of the secondary packaging should there be leakage from the primary receptacle.
- The secondary packaging must be marked with the international biohazard symbol.

Outer packaging

- The secondary packaging must fit securely in a rigid outer container such as a fireboard box not less than 3.9" x 3.9" in dimension.
- The outer container must be marked Exempt human or Exempt animal specimen.

Not Regulated (USPS)

Specimens defined as not regulated under the USPS Publication 52, Packaging Instruction 6G include: transfusion/transplant material, dried specimens including blood spots and feces, biological product, agricultural product, or forensic material containing a biological material not expected to contain a Category A or Category B infectious substance transported on behalf of a U.S. Government agency or a state, local, or Indian tribal government agency.

Dry Ice-Carbon Dioxide Solid (USPS)

Dry ice shipped by air transport must be packaged according to USPS Publication 52, Packaging Instruction 9A. In general, dry ice must be packaged in container that is designed and constructed to permit the release of carbon dioxide gas and prevent pressure build up within the package. Containers must conform to DOT 49 CFR, Sections 173.217 and 175.10. In addition, air transport requires that each mail piece not contain more than 5 pounds of dry ice.

Proper Shipping Name and UN Number

The proper shipping name Dry ice or Carbon Dioxide solid along with the proper UN number UN1845 must be used with packages.

Markings (air transport)

- The outer container must have the following labels and markings: UN 1845
- Class 9 hazards label
- The net quantity of dry ice in each package
- Name and address of submitter and consignee.

Dry Ice-Carbon Dioxide Solid (USPS) cont'd.

Documentation (air transport)

- A shipper's dangerous goods declaration filled out in triplicate
- Proper shipping name of Dry Ice or Carbon Dioxide Solid
- Class 9 label
- The net quantity of dry ice in each package
- The number of packages

For surface transportation, the amount of dry ice per mail piece may exceed 5 pounds.

Markings (surface transportation)

- "Carbon Dioxide Solid" or "Dry Ice"
- "Surface Only" or "Surface Mail Only"
- The net weight of the dry ice and the identity of the contents being cooled.
- A shipper's declaration and a DOT Class 9 warning label are not required for surface transport of dry ice.

Department of Transportation Hazardous Materials Regulations (DOT HMR)

Category A Infectious substances (DOT)

Proper Shipping Name and UN Number

All Category A infectious substances must meet the triple packaging requirements of DOT 49 CFR 173.196. The proper shipping name if it is infectious for humans or humans and animals is Category A infectious substance infecting humans and is designated with a UN number of UN2814. If it is infectious for animals only, the proper shipping name is Category A infectious substance affecting animals with a UN number of UN 2900.

Category A Required Packaging

Primary Receptacle

- The specimen material must be packaged in a leak proof securely sealed primary receptacle.
- If the primary container contains a solid it must be sift proof.

Absorbent and Cushioning Material

Absorbent material must surround the primary receptacle or be otherwise configured to take up all of the liquid content in the primary receptacle in case of leakage. Sufficient cushioning material to withstand shock and pressure changes must surround the primary receptacle.

Category A Infectious substances (DOT)

Secondary Packaging

- The primary receptacle and the absorbent cushioning must be enclosed in a secondary packaging that has a leak proof barrier capable of preventing the failure of the secondary packaging should there be leakage from the primary receptacle.
- Either the secondary or primary container must be capable of withstanding an internal pressure differential of not less than 95kPa pressure without leakage.
- The secondary packaging must be marked with the international biohazard symbol.

Itemized List of Contents

An itemized list of contents must be included between the secondary and outer packaging.

Outer Packaging

- The packaging must be capable of successfully passing the drop tests of at least 35 ft and must meet UN 6.2 certification.
- At least one surface of the outer packaging must have a minimum dimension of 100 mm by 100 mm (3.9 inches).

Markings

- Category A Infectious substance label
- U.N. specification certification
- Class 6.2 Infectious substance diamond
- Orientation arrows (if greater than 50mL)
- Name and 24/7 contact number of responsible person
- Shipper and Consignee name and address

Documentation

DOT does not require a specific type of shipping paper. The IATA dangerous goods form may be used or a shipping paper may be developed. Section 172.202 of 49 CFR contains type & sequence of required information.

Category B Infectious substances (DOT)

Proper Shipping Name and ID Number

All Category B infectious substances must meet the triple packaging requirements of DOT 49 CFR 173.199. The proper shipping name Category B infectious substances is Biological substance, Category B and packages must be marked with the UN3373 identification number.

Category B Infectious substances (DOT) cont'd.

Category B Specimen Required Packaging

Primary Receptacle:

- The specimen material must be packaged in a leak-proof primary receptacle. Parafilm may be used to ensure that specimen is sealed and leak-proof/siftproof.
- If the primary container contains a solid it must be sift proof.
- The volume in a single primary receptacle may not exceed 1 liter.
- Two or more primary receptacles whose total volume does not exceed 4L or 4kg may be enclosed in a secondary container.

Absorbent and Cushioning Material

Absorbent material must surround the primary receptacle or be otherwise configured to take up all of the liquid content in the primary receptacle in case of leakage. Sufficient cushioning material to withstand shock and pressure changes must surround the primary receptacle.

Secondary Packaging

- The primary receptacle and the absorbent cushioning must be enclosed in a secondary packaging that has a leak proof barrier capable of preventing the failure of the secondary packaging should there be leakage from the primary receptacle.
- Either the secondary or primary container must be capable of withstanding an internal pressure differential of not less than 95kPa pressure without leakage.
- The secondary packaging must be marked with the international biohazard symbol.

Outer Packaging (referenced from 49 CFR 173.199):

- The outer package must be sturdy and rigid so that the entire package is able to withstand normal transportation and handling without release of hazardous material into the environment.
- The packaging must be capable of successfully passing the drop tests of at least 1.2 meters (3.9 feet) without leakage from the primary receptacle.
- At least one surface of the outer packaging must have a minimum dimension of 100 mm by 100 mm (3.9 inches).

Markings

- The address side of the mail piece must be clearly marked Biological Substance Category B and must be marked with the correct UN number (UN3373).
- Orientation arrows may be used but are not required.
- A name and phone number of a responsible person familiar with the contents and having emergency response information must be included on the outside of the package.
- Shipper and Consignee name and address

Not Regulated by Division 6.2 Regulations (DOT)

This category includes human or animal specimen that are being transported for routine testing not related to an infectious disease. These specimens include those which there is a low probability of the sample being infectious. These samples are not subject to hazardous material regulations.

Dry Ice-Carbon Dioxide Solid (DOT)

Dry ice shipped by air transport must be packaged according to DOT 49 CFR, Section 173.217. In general, dry ice must be packaged in container that is designed and constructed to permit the release of carbon dioxide gas and prevent pressure build up within the package such as a Styrofoam container. Caution: The styrofoam container must not be sealed as this would cause the package to explode.

Proper Shipping Name and UN Number

The proper shipping name Dry ice or Carbon Dioxide solid along with the proper UN number UN1845 must be used with packages submitted for air transport

Markings

- The outer container must have the following labels and markings:
- UN 1845
- Class 9 hazard label
- The net quantity of dry ice in each package
- Name and address of submitter and consignee.

Documentation

Documentation on a Dangerous Goods Form is required only when used as a refrigerant for other Dangerous Goods. Otherwise, the airway bill must contain the following information:

- The proper UN number (UN1845)
- Proper shipping name of Dry Ice or Carbon Dioxide Solid
- Class 9
- The net quantity of dry ice in each package
- The number of packages

International Civil Aviation Organization / International Air Transport Association Dangerous Goods Regulations (ICAO/IATA)

Category A Infectious substances (ICAO/IATA)

Proper Shipping Name and UN Number

All Category A infectious substances must meet the triple packaging requirements of IATA Packing Instruction 620. The proper shipping name if it is infectious for humans or humans and animals is Category A infectious substance infecting humans and is designated with a UN number of UN2814. If it is infectious for animals only, the proper shipping name is Category A infectious substance affecting animals with a UN number of UN 2900.

Category A Specimen Required Packaging (ICAO/IATA)

Primary Receptacle

- The specimen material must be packaged in a leak proof securely sealed primary receptacle.
- If the primary container contains a solid it must be sift-proof.

Absorbent and Cushioning Material

Absorbent material must surround the primary receptacle or be otherwise configured to absorb the entire liquid content in the primary receptacle in case of leakage. Sufficient cushioning material must surround the primary receptacle to prevent movement during transport and to withstand shock and pressure changes.

Secondary Packaging

- The primary receptacle and the absorbent cushioning must be enclosed in a secondary packaging that has a leak proof barrier capable of preventing the failure of the secondary packaging should there be leakage from the primary receptacle.
- Either the secondary or primary container must be capable of withstanding an internal pressure differential of not less than 95 kPa pressure without leakage.
- The secondary packaging must be marked with the international biohazard symbol.

Itemized List of Contents

An itemized list of contents must be included between the secondary and outer packaging of Category A specimens.

Outer Packaging

- The packaging must be capable of successfully passing the drop tests of at least 35 ft and must meet UN 6.2 certification.
- At least one surface of the outer packaging must have a minimum dimension of 100 mm by 100 mm (4"x4").

Category A Specimen Required Packaging (ICAO/IATA) cont'd.

Markings

The outer container must have the following labels and markings:

- Shipper and Consignee name and address
- Category A Infectious substance label
- U.N. specification certification
- Class 6.2 Infectious substance diamond
- Orientation arrows (if greater than 50mL)
- Name and 24/7 contact number of responsible person

Documentation

- The Shipper's Declaration Form must be filled out completely and accurately.
- The form must have a red border and must be submitted on the outside of the package. The shipper must always keep at least one copy of the form.
- Commercial shipping companies such as Fed-Ex have additional requirements including that form completion in electronic software that has proofreading capability as well as a specific number of copies required for shipment. These shippers should be consulted prior to submitting dangerous goods for shipping.
- Resource: Guide for Preparing Shipping Papers
https://hazmatonline.phmsa.dot.gov/services/publication_documents/Guide%20for%20Preparing%20Shipping%20Papers.pdf

Category B Infectious substances (ICAO/IATA)

Proper Shipping Name and ID Number

All Category B infectious substances must meet the triple packaging requirements of IATA Packing Instruction 650. The proper shipping name Category B infectious substances is Biological substance, Category B and must be marked with the UN3373 identification number.

Category B Specimen Required Packaging (ICAO/IATA)

Primary Receptacle

- The specimen material must be packaged in a leak proof primary receptacle.
- If the primary container contains a solid it must be sift proof.
- The volume in a single primary receptacle may not exceed 1 liter.
- Two or more primary receptacles whose total volume does not exceed 4L or 4kg may be enclosed in a secondary container.

Absorbent and Cushioning Material

Absorbent material must surround the primary receptacle or be otherwise configured to take up all of the liquid content in the primary receptacle in case of leakage. Sufficient cushioning material to withstand shock and pressure changes must surround the primary receptacle.

Category B Specimen Required Packaging (ICAO/IATA) cont'd.

Secondary Packaging

- The primary receptacle and the absorbent cushioning must be enclosed in a secondary packaging that has a leak proof barrier capable of preventing the failure of the secondary packaging should there be leakage from the primary receptacle.
- Either the secondary or primary container must be capable of withstanding an internal pressure differential of not less than 95kPa pressure without leakage.
- The secondary packaging must be marked with the international biohazard symbol.

Itemized List of Contents

An itemized list of contents must be included between the secondary and outer packaging of Category B specimens. It should be protected by placing inside a Ziploc bag. Include the net quantity of hazardous materials on this documentation.

Outer Packaging

- The outer package must be sturdy and rigid so that the entire package is able to withstand normal transportation and handling without release of hazardous material into the environment.
- The packaging must be capable of successfully passing the drop tests of at least 1.2 meters (3.9 feet) without leakage from the primary receptacle.
- At least one surface of the outer packaging must have a minimum dimension of 100 mm by 100 mm (4"x4").

Exempt Human/Animal Specimens (ICAO/IATA)

The Exempt category includes human or animal specimen that are being transported for routine testing not related to an infectious disease. These specimens include those in which there is a low probability of the sample being infectious as determined through professional judgment taking into consideration known medical history, symptoms and source information, human or animal and local endemic local conditions. These samples are not subject to hazardous material regulations but must meet packaging requirements found in IATA 3.6.2.2.3.6.

Exempt Specimens-Required packaging (ICAO/IATA)

Primary Receptacle

- The specimen material must be packaged in a durable and securely sealed primary receptacle. If the primary container contains a solid it must be sift proof.
- The volume in a single primary receptacle may not exceed 500mL or 500g if a solid.
- Two or more primary receptacles whose total volume does not exceed 500mL or 500g may be enclosed in a secondary container.

Exempt Specimens-Required packaging (ICAO/IATA) cont'd.

Absorbent and Cushioning Material

Absorbent material must surround the primary receptacle or be otherwise configured to take up all of the liquid content in the primary receptacle in case of leakage. Sufficient cushioning material to withstand shock and pressure changes must surround the primary receptacle.

Secondary Packaging

- The primary receptacle and the absorbent cushioning must be enclosed in a secondary packaging that has a leak proof barrier capable of preventing the failure of the secondary packaging should there be leakage from the primary receptacle.
- The secondary packaging must be marked with the international biohazard symbol.

Outer packaging

- The secondary packaging must fit securely in a rigid outer container such as a fireboard box not less than 4x4" in dimension.
- The outer container must be marked "Exempt Human Specimen" or Exempt Animal Specimen".

Not Regulated (ICAO/IATA)

Specimens defined as not regulated under IATA dangerous goods regulations include: samples that are sterile/killed or inactivated, organisms that are non-pathogenic for humans/animals, environmental samples, transfusion/transplant material, dried specimens including blood spots and feces, biological product, agricultural product, or contaminated materials such as laundry or medical equipment. Note that specimens that are not regulated by DOT may be subject to other agency requirements, such as Occupational Safety and Health Association (OSHA).

Dry Ice or Carbon Dioxide, Solid (ICAO/IATA)

Dry ice shipped by air transport must be packaged according to IATA Packing instruction 954. In general, dry ice must be packaged in container that is designed and constructed to permit the release of carbon dioxide gas and prevent pressure build up within the package such as an unsealed Styrofoam container.

Dry Ice Proper Shipping Name and UN Number

The proper shipping name Dry ice or Carbon Dioxide solid along with the proper UN number UN1845 must be used with packages submitted for air transport

Dry Ice or Carbon Dioxide, Solid (ICAO/IATA) cont'd.

Dry Ice Markings

The outer container must have the following labels and markings:

- UN 1845
- Class 9 hazards label
- The net quantity of dry ice in each package

Dry Ice Documentation

Documentation on a Dangerous Goods Form is required only when used as a refrigerant for other Dangerous Goods. Otherwise, the airway bill must contain the following information.

- The proper UN number (UN1845)
- Proper shipping name of Dry Ice or Carbon Dioxide Solid
- Class 9
- The net quantity of dry ice in each package
- The number of packages

Packaging and Shipping Resources

DOT Hazardous Materials Hotline 1-800-467-4922

DOT Emergency Response Handbook

<https://www.phmsa.dot.gov/sites/phmsa.dot.gov/files/docs/ERG2016.pdf>

DOT Materials of Trade Brochure

https://www.phmsa.dot.gov/sites/phmsa.dot.gov/files/docs/MOTS%20brochure%202007_10_02.pdf

DOT Security Requirements Training Module 7,

REGISTER: <http://dothazmat.vividlms.com>

DOT Title 49 CFR: Transportation Regulations

[https://www.ecfr.gov/cgi-bin/text-](https://www.ecfr.gov/cgi-bin/text-idx?sid=ca3d88e943c9b3619f96ac3d22f1c200&c=ecfr&tpl=/ecfrbrowse/Title49/49cfrv3_02.tpl)

[idx?sid=ca3d88e943c9b3619f96ac3d22f1c200&c=ecfr&tpl=/ecfrbrowse/Title49/49cfrv3_02.tpl](https://www.ecfr.gov/cgi-bin/text-idx?sid=ca3d88e943c9b3619f96ac3d22f1c200&c=ecfr&tpl=/ecfrbrowse/Title49/49cfrv3_02.tpl)

DOT Transporting Infectious Substances Safely (PHMSA PHH 50-00-79-0706)

https://www.phmsa.dot.gov/sites/phmsa.dot.gov/files/docs/Transporting_Infectious_Substances_brochure.pdf

Federal Express (ICAO/IATA)

For additional guidance using Federal Express please consult the Fed-Ex Website for Dangerous Goods, Hazardous Materials, or Ship Manager software

<http://www.fedex.com/us/services/options/index.html>

IATA Hotline 1-514-390-6770

Pipeline and Hazardous Materials Safety Administration

<http://www.phmsa.dot.gov/>

US Postal Service

<http://www.usps.com/>

Search “Publication 52: Hazardous, Restricted, & Perishable Mail” in the search box on the upper right corner of the home page and select “Publication 52: Hazardous, Restricted, & Perishable Mail” at the top of the results page to be directed to the postal regulations. Revisions are posted as they are made available.