

Intranasal Administration of Naloxone for Suspected  
Opiate Overdose

# GBI NALOXONE TRAINING PROGRAM

# Objectives



- Overview of the problem
- HB 965
- What is an Opiate
  - Abuse
  - Side effects
  - Overdose indicators
- What is Naloxone (Narcan)
- Intranasal application

# Objectives

- ① Assembly and administering intranasal Naloxone
- ① Side effects
- ① GBI program
- ① GBI reporting procedures

# Background



- ⦿ Alarming rise in unintentional opioid related deaths.
- ⦿ Some opioids are prescription medications.
- ⦿ Other opioids are illegal like heroin.
- ⦿ As law enforcement officers we are risk of being exposed.
- ⦿ Fentanyl, in powder form, can be absorbed through the skin or inhaled.

# GBI Stats



- 2013 – 32 heroin related deaths with a combination of another drug. No fentanyl detected.
- 2014 – 49 heroin related deaths with a combination of another drug. 6 of these cases included fentanyl combined with the heroin.

# HB 965 –

## Georgia 911 Medical Amnesty Law

- What it provides for:
  - Adds new code section to chapter 13 of Title 16 – 16-13-5
    - Person seeking medical assistance for a drug overdose themselves or another shall not be arrested, charged, or prosecuted for the following violations of law:
      - possession of a controlled substance if the aggregate weight, including any mixture, is less than four grams of a solid substance, less than one milliliter of liquid substance, or if the substance is placed onto a secondary medium with a combined weight of less than four grams
      - possession of less than one ounce of marijuana; or
      - possession and use of drug related objects.
      - violation of a permanent or temporary protective order or restraining order
      - violation of a condition of pretrial release, condition of probation, or condition of parole based on a drug violation.

# HB 965 –

## Georgia 911 Medical Amnesty Law

- ◉ What it provides for:
  - Adds new subsection to 3-3-23 – Under 21 possession of alcohol
  - Person seeking medical assistance for someone who is experiencing an alcohol related overdose shall not be arrested, charged, or prosecuted for a violation of paragraphs (2) through (5) of subsection (a) of this Code section
  - Person who is experiencing an alcohol related overdose and seeks medical assistance for himself or herself or is the subject of such shall not be arrested, charged, or prosecuted for a violation of paragraphs (2) through (5) of subsection (a) of this Code section 284
  - Persons shall also not be arrested, charged or prosecuted for violation of a permanent or temporary protective, probation or parole violation, or pretrial release

# HB 965 –

## Georgia 911 Medical Amnesty Law

- This law provides for the protection against arrest or prosecution of said laws IF:

**The evidence for the arrest,  
charge, or prosecution of such  
violation resulted from seeking  
such medical assistance**

Law became effective April 24, 2014



# HB 965 –

## Georgia 911 Medical Amnesty Law

- What it provides for:
  - Amends Article 6 of Chapter 4 of Title 26 by adding law enforcement agencies in the definition of “first responder”
  - Practitioner may prescribe an opioid antagonist to a law enforcement agency
  - Pharmacist may dispense opioid antagonists to a law enforcement agency with a prescription
  - **Officers may administer opioid antagonists to a person suspected of experiencing an opiate related overdose**
  - **Protects from criminal or civil liability for administering an opioid antagonist**

# HB 965 –

## Georgia 911 Medical Amnesty Law

- ⦿ What it provides for:
  - Amends OCGA 31-11-55 by adding new code section (31-11-55.1)
  - Officers who carry opioid antagonist must receiving training in accordance with rules and regulations of the Department of Public Health
  - Agencies shall notify EMS services that officers are equipped with opioid antagonist
  - Officers who administer or provide an opioid antagonist shall make available a printed or electronically stored report to the licensed ambulance service which transports the patient

# Officer Safety



- Officer safety is paramount. If at any given time you feel your life, or others is in danger then scene safety and security will take precedence. You cannot help if you yourself are in need of help, or in danger.



# Why now?

- Georgia is the 19<sup>th</sup> state to allow LLE to administer Naloxone (Narcan)
- Began in 2004 with New Mexico State Police
- LLE many times first on scene
- Public Relations
  - “Why aren't you doing anything?!?”
  - Improved public image
- LLE is becoming an accepted member of the First Responder Community

# Sources of Medications

## Source of Pain Relievers for Most Recent Nonmedical Use Among Past Year Users 12 and Older

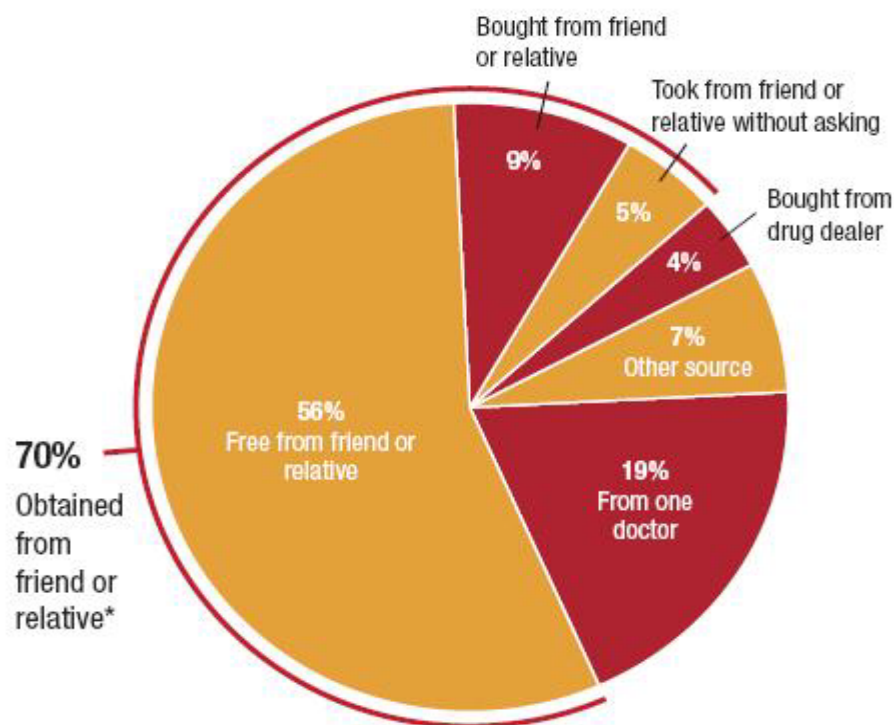

Past Year Nonmedical Users of Pain Relievers: 12.6 million

\*Percentage from friend or relative is derived before rounding of individual sources.  
Source: SAMHSA, 2006 National Survey on Drug Use and Health (September 2007).



# National Statistics



For every death:

- 10 Hospital admissions
- 32 ER visits
- 130 Dependent users
- 825 non-medical users
- 1 in 20 over the age of 12 have used
- 15,000 near fatal overdoses (2010)
- 40% of calls to Poison Centers

# Overdose deaths



- ◎ 78% of the deaths are unintentional
  - Recreational/new users
  - Geriatric populations
  - Pediatric populations
- ◎ 14% Suicide
- ◎ 8% Unknown

# Current GBI Data

## Deaths from Drug Overdose 2012

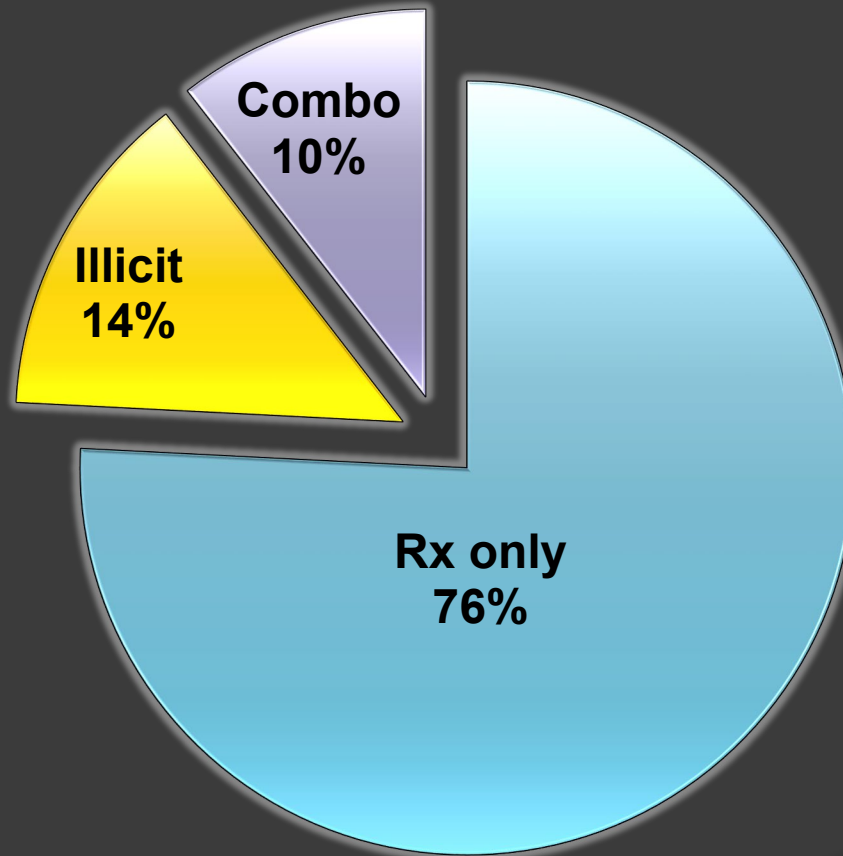



# Opiates



- ⦿ Synthetic or naturally occurring
- ⦿ Binds with receptors in the brain
  - Induce sedation
  - Block perception of pain

# Opiates

- ◎ Primary use for opiates
  - Pain management
  - Considered a benchmark for modern medicine
  - Comfort measures



# Opiates of Abuse



- Opium
- Codeine
- Morphine
- Tramadol (Ultram)
- Methadone
- Buprenorphine (Subutex)
- Propoxyphene (Darvocet)
- Pethidine (Demerol)
- Hydrocodone (Lortab/Vicodin)
- Oxycodone (Percocet, Oxycontin)
- Hydromorphone (Dilaudid)
- Oxymorphone (Opana)
- Fentanyl
- (Illegal) Heroin (diacetylmor)

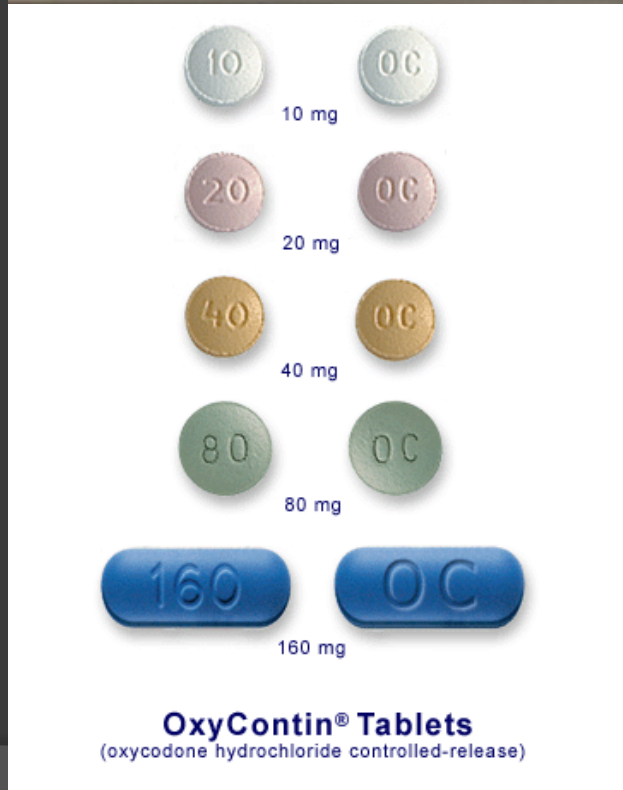
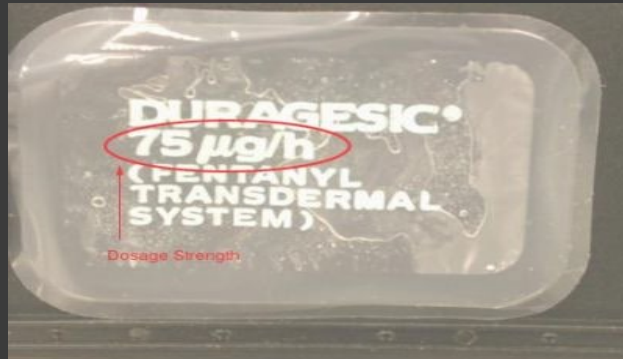

# Fentanyl

- ⦿ Schedule II Narcotic. Analgesic/anesthetic
- ⦿ Most potent opioid available for medical use.
- ⦿ 50-100 times more potent than morphine.
- ⦿ 30-50 times more potent than heroin.
- ⦿ Potentially lethal at low levels. 0.25mg can be fatal.
- ⦿ Can be absorbed through skin and accidental inhalation.
- ⦿ Commonly used to lace heroin.

# Opiates

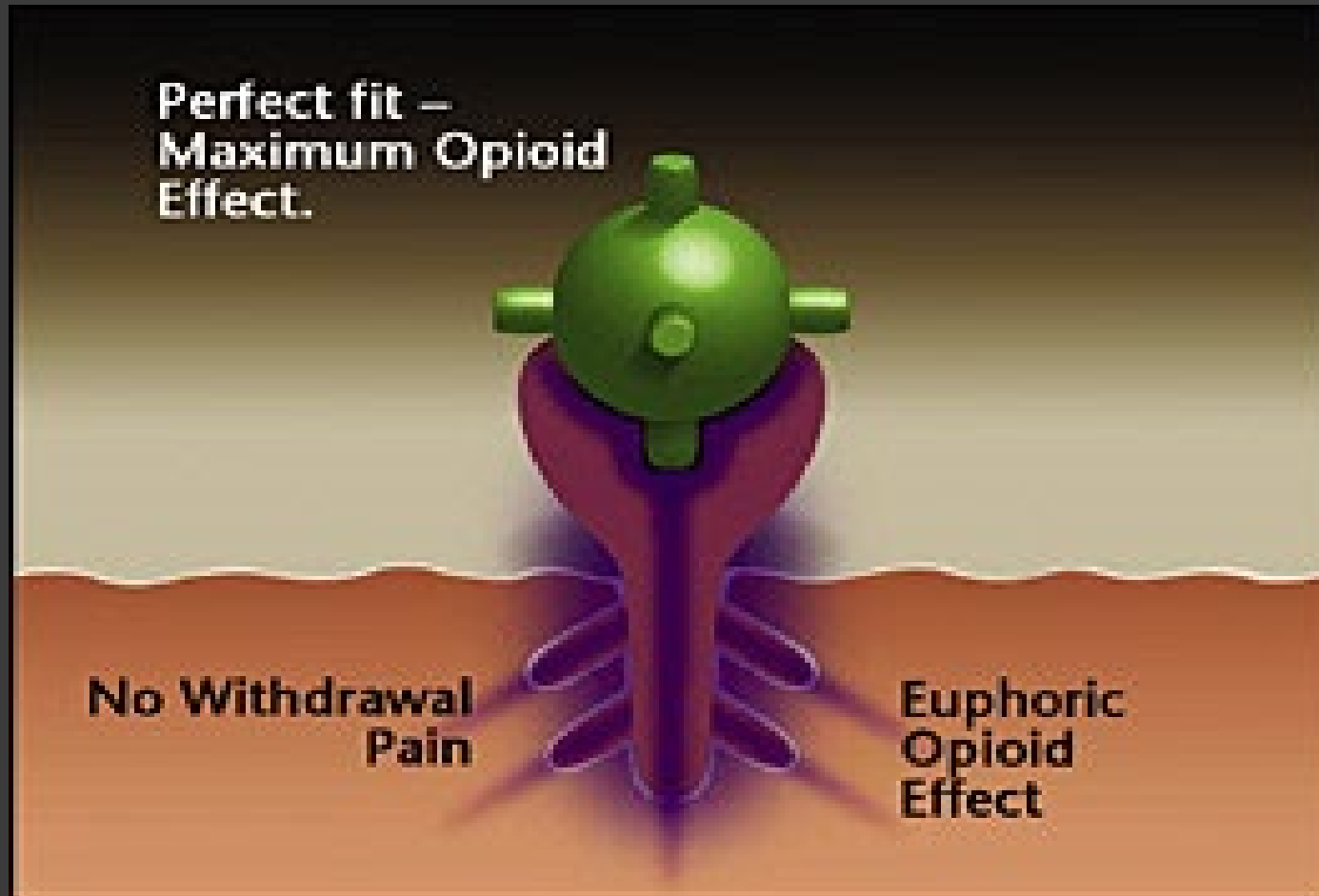

# Side Effects of Opiates



- Euphoria
- Sedation
- Decreased respiratory rate
- Pin point pupils
  - Meperidine (Demerol), and Propoxyphene (Darvon)  
*Will cause dilated pupils*



# Overdose Indicators

- ⦿ Decreased level of consciousness
- ⦿ Pin Point or Dilated pupils
- ⦿ Sweaty
- ⦿ Unconsciousness
- ⦿ Decreased respiratory rate
- ⦿ Cardiac arrest

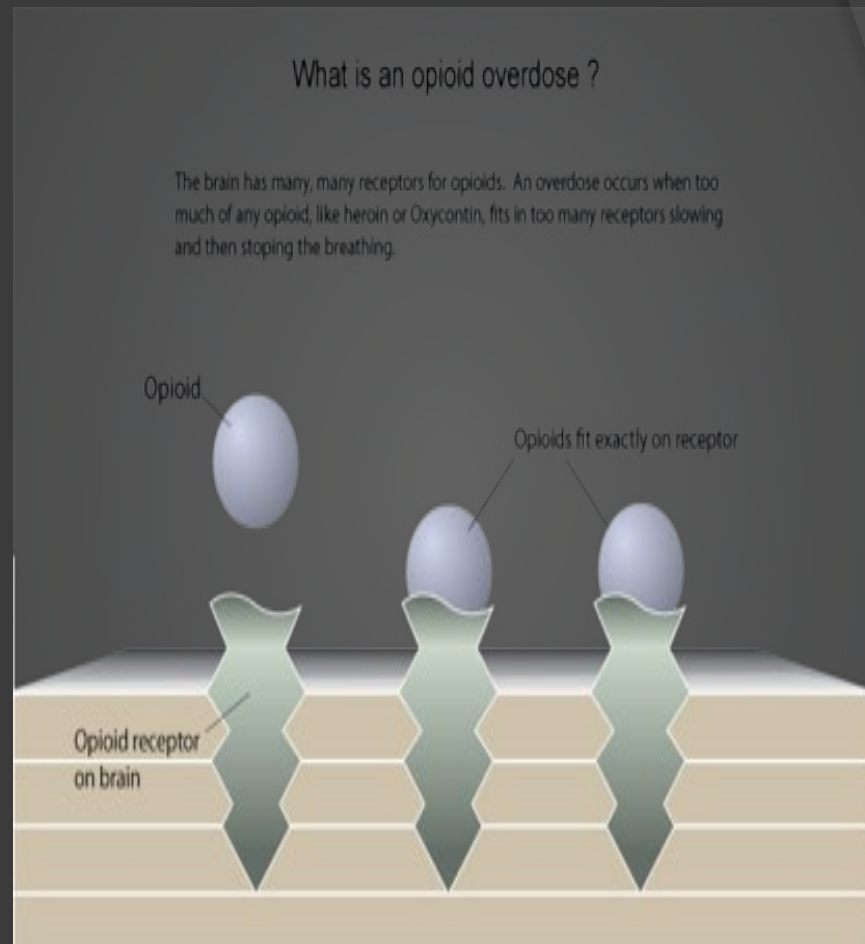

# Hypoxia



- ⦿ Lack of oxygen to the vital organs
  - Brain, heart, lungs and kidneys
- ⦿ Hypoxic brain injury can occur within 4 to 6 minutes
  - Pupillary dilatation
- ⦿ Cyanosis a pale, or bluish color
  - Lips
  - Nail beds



# Cyanosis



**Blue Lips**



**Fingertips**



# *Typically, When Does an Overdose Occur?*

- ⦿ High potency heroin (injected or inhaled)
- ⦿ Poly-substance overdose-typically alcohol and benzodiazepines in addition to heroin.
- ⦿ Decreased tolerance after period of abstinence; release from jail, relapse after detox/recovery.

# Narcan (Naloxone)

- Opioid antagonist
- Reverses opioid overdose by competing for opioid receptors in the CNS
- Onset of action 1 to 2 minutes
- Given intranasal
- Low risk for blood borne exposure
- No risk if given in absence of opioids

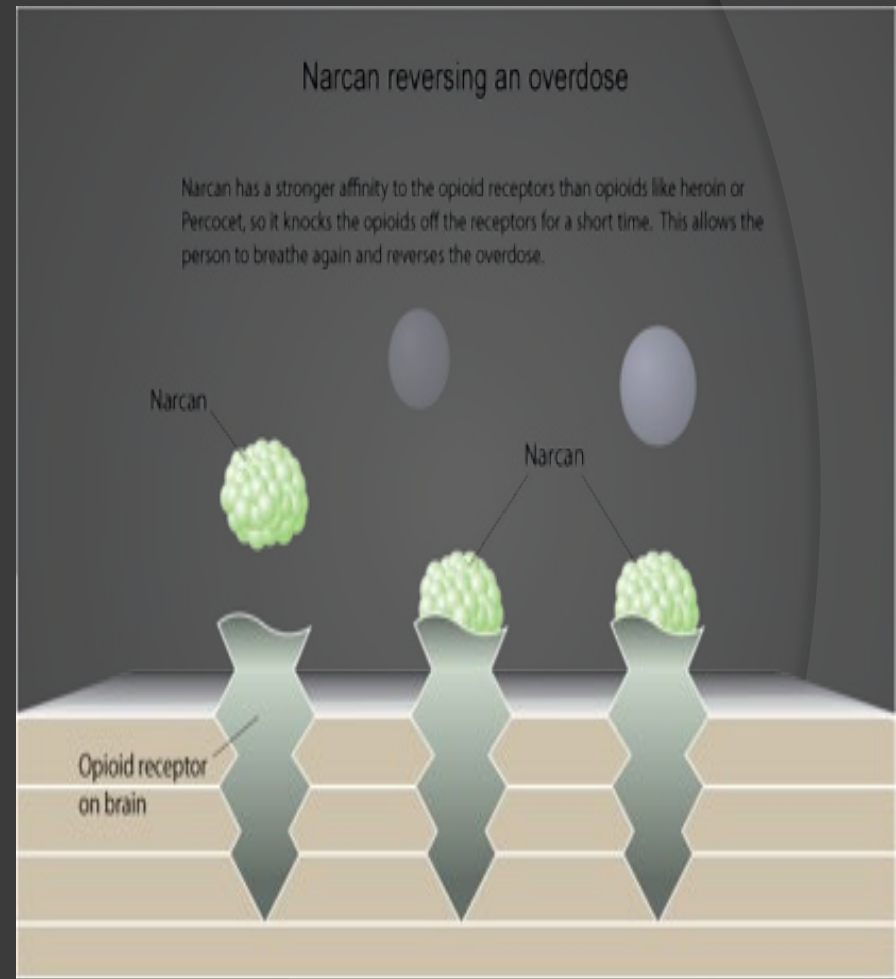

# Narcan (Naloxone)



- Primary goal for administration is to increase respiratory rate and further reduce or prevent damage caused by hypoxia.
- Not intended for total reversal

# Intranasal Naloxone (Narcan)



# Intranasal Medication Administration: Basic Concepts



- ◎ This delivery route has several advantages:
  - Its easy and convenient
  - Almost everyone has a nose
  - The nose is a very easy access point for medication delivery
  - No special training is required to deliver the medication
  - No shots are needed
  - It is painless
  - It eliminates any risk of a needle stick *to you, the medical provider*

**Intranasal Naloxone (Narcan)  
For Law Enforcement Officer**

**GBI's Protocol  
May 2015**

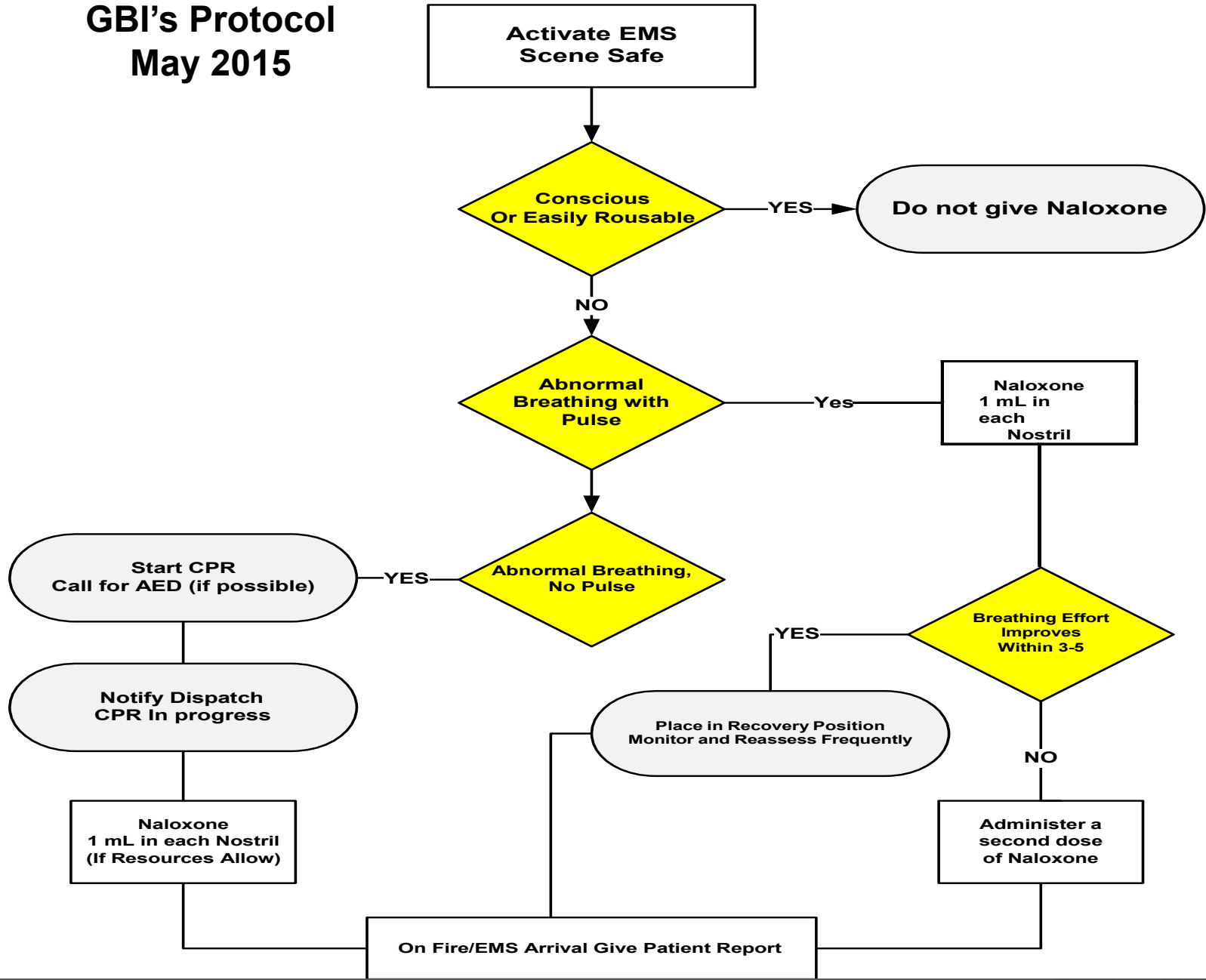

# Side Effects of Full Reversal

- Agitation, confusion, hostility
- Vomiting
- Profuse sweating
- Cardiac arrest (rare)





# Naloxone has no effect on...

- Benzodiazepines
- Sympatometics
- Marijuana
- Sleep agents
- Alcohol
- Point to remember: Most users, whether recreational , habitual, or accidental have ingested two or more substances.



# Overdose Mimics

- Strokes
- Hypoglycemia (low blood sugar)
- Infection



# GBI Kits



# GBI Kits

CPR Face Shield

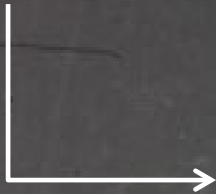

Mucosal Atomization Device (MAD)

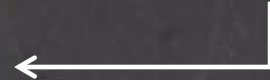

Gloves



Naloxone

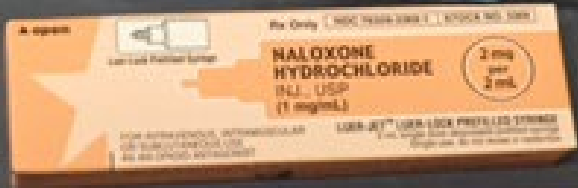

Documentation

A white documentation card for 'Intranasal Naloxone'. The card has a header with 'Intranasal Naloxone' and 'Naloxone HCl'. Below the header, it says 'Use Documentation Card'. The card contains several lines for handwritten information: 'Date: \_\_\_\_\_ Time: \_\_\_\_\_', 'Exp. Number: \_\_\_\_\_', 'Badge Number: \_\_\_\_\_', 'Location: \_\_\_\_\_', and 'Notes: \_\_\_\_\_'.

# Components of Intranasal NALOXONE



# Administration of Naloxone

- Atomization
- Similar to OTC nasal sprays
- Effective and easy

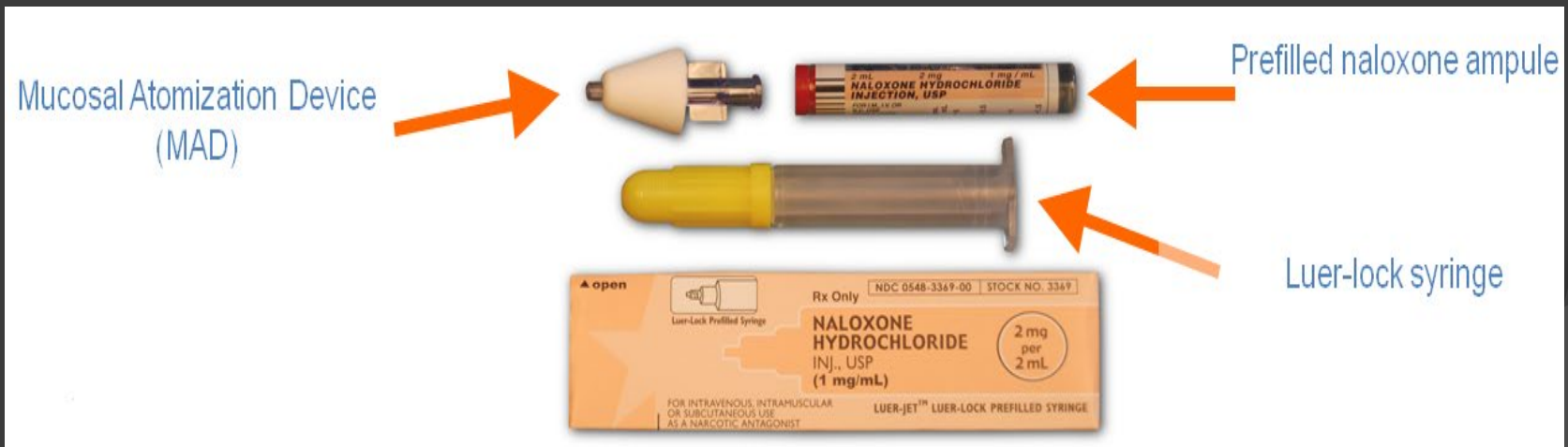

# Basic anatomy of the nose

## Olfactory Bulb

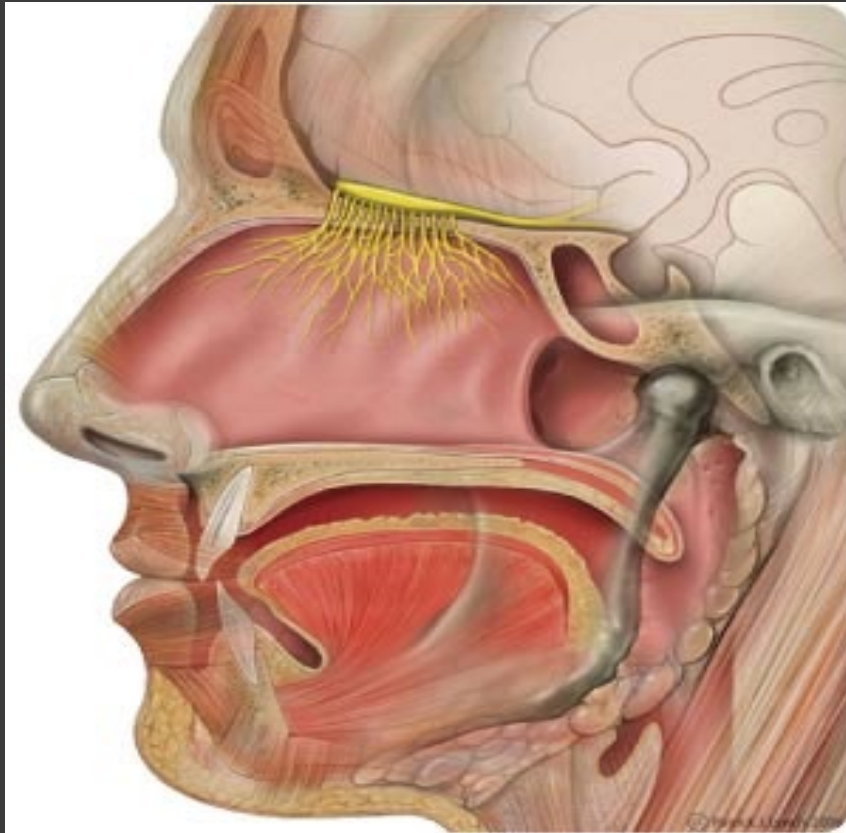

## Blood vessels

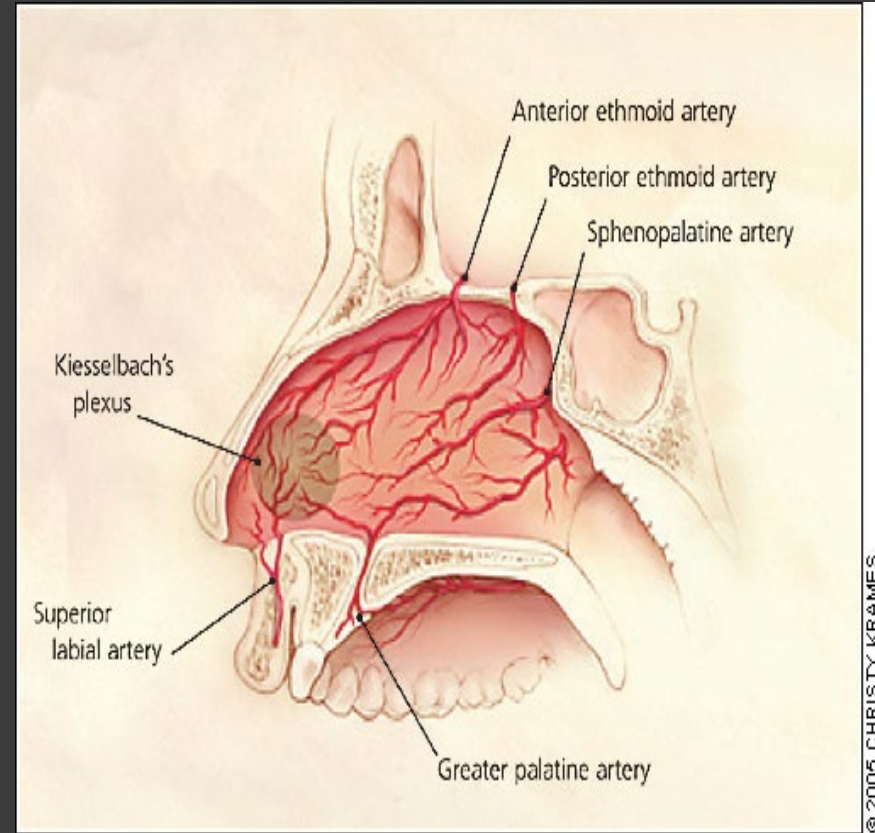

# How to Assemble

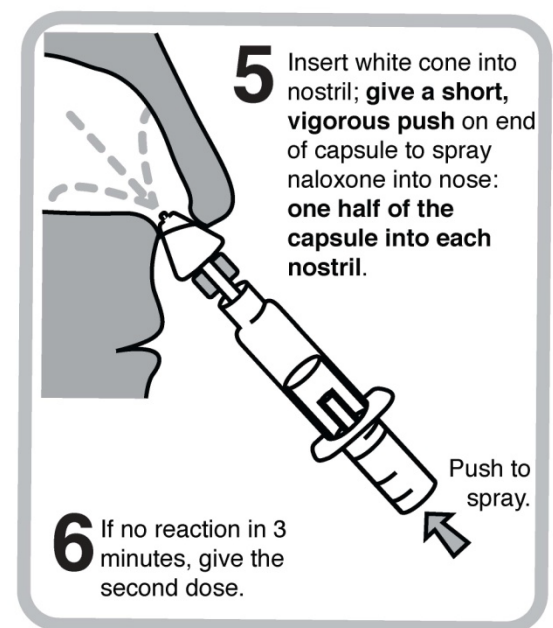
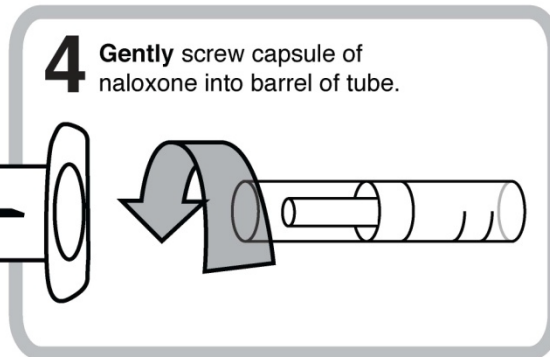
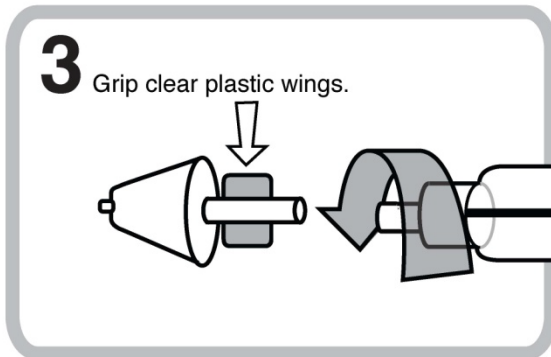
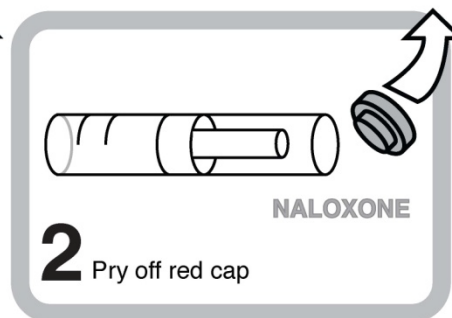
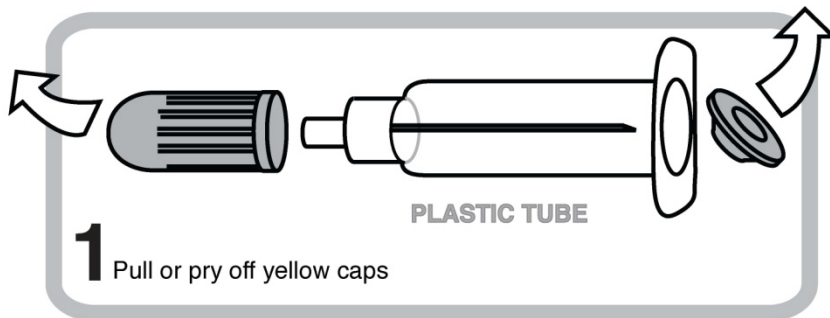

**6** If no reaction in 3 minutes, give the second dose.

Source: HarmReduction.org



# Administering Naloxone

Atomized  
Mist



# Administering Naloxone



- Assemble prefilled syringe and attach MAD.
- Choose a nostril.
- Gently insert MAD.
- Firmly and steadily push syringe administer only half the volume, 1mg/ml, in one nostril.
- Administer the other half, 1mg/ml, in the other nostril. Total dose-2mg/ml.
- If expected changes occurs place individual in recovery position.

# Recovery position



# Barriers to absorption

- Prolonged abuse
- Nasal discharge
- Use of vasoconstrictors
- Debris (dust, powders)
- Trauma
- Too much volume delivered



# Prehospital Intranasal Naloxone

- Take away lessons for nasal naloxone:

Dose and volume – 1mg per nostril.

Delivery – immediately on decision to treat inject Naloxone into nose with MAD, then begin standard care. Recovery position.

Successful awakening eliminates the need for further administration of Naloxone. Continue supportive care and await EMS.

Awakening is gradual, but adequate respiratory efforts occur as fast or faster than IV Naloxone due to no delays with IV start.

Not 100% effective so failures with intranasal naloxone need to be followed one additional dose after 3-5 minutes.

# GBI Naloxone Program



- GBI Policy
- Each sworn Agent will be issued a kit.
- Crime lab personnel – 1 kit in each branch lab and multiple at HQ.
- Dr. Kris Sperry – Medical Director
- SAC Wayne Smith – Agency Coordinator
- Leigh Champion – Lab Safety Officer

# Reporting Procedures



- Following naloxone administration, GBI personnel shall submit a Naloxone Administration Incident Report to his or her supervisor or Special Agent in Charge detailing at a minimum the following:
  - The nature of the incident;
  - The care the patient received; and
  - The fact that naloxone was administered
- A copy should be provided to EMS

# Reporting Procedures



- A copy of the naloxone incident report will be forwarded to the agency coordinator. All reports may be submitted via hardcopy or electronically. The program coordinator will maintain these reports in a digital format under the Investigative Section of GBIWEB.
- Personnel who administer naloxone shall generate a case number for the incident regardless if the naloxone is administered to a citizen or a GBI employee. All investigative division personnel should utilize the current case number if the incident is part of an ongoing investigation or initiate an Assistance Rendered if an isolated incident. A copy of the incident report shall be included in the case file.



# Conclusion



- Cost effective ways to save a life
- Law enforcement is becoming more involved with first response
- Often are on scene before EMS
- Current trends of opiate use and abuse support the need of this program.
- ***Intranasal is a true “needleless” system!***
  - Reduce Level III bloodborne exposures
    - HIV
    - Hepatitis B, C