

## **SECTION Q - VENTILATION:**

### **REFERENCES**

#### **Chapter 511-6-1:**

- .05 Equipment and Utensils. Amended. (2) Design and Construction (j) Ventilation Hood Systems, Filters.
- .05 Equipment and Utensils. Amended. (2) Design and Construction (n) Exhaust Ventilation Hood System.
- .05 Equipment and Utensils. Amended. (3) Design and Construction (d) Ventilation Hood Systems, Adequacy.
- .05 Equipment and Utensils. Amended. (5) Acceptability of Existing Equipment.
- .07 Physical Facilities. (2) Design, Construction, and Installation (j) Heating, Ventilating, Air Conditioning, Systems Vents.
- .07 Physical Facilities. (3) Numbers and Capacities. (g) Mechanical Ventilation.
- .07 Physical Facilities. (5) Maintenance and Operation. (d) Cleaning Ventilation Systems, Nuisance and Discharge Prohibition.

#### **Life Safety Codes:**

NFPA 96, 2004 Edition, Standard for Ventilation Control and Fire Protection of Commercial Cooking Operations.  
NFPA 101, 2000 Edition, Life Safety Code.  
International Fire Code (IFC), as adopted by the Chapter 120-3-3 of the Rules and Regulations State Minimum Fire Safety Standards.

**I. Purpose:** The purpose of this section is to serve as a basic reference document. It is to provide background information and reasonable assurance that proposed exhaust ventilation systems are thoughtfully included in the commercial kitchen design relative to good sanitation of equipment and facilities. *It is not intended to supersede or replace professional engineering standards and methodologies, state law or local codes in regards to proper design, construction, installation, or approval of ventilation systems in food service establishments.* It will be the food service permit applicant's (or as necessary, the permit holder's) responsibility to provide written documentation of satisfactory compliance with all applicable standards, rules and regulations, laws and codes in regards to the establishment – *see DPH Rule 511-6-1-.02(1)(c)2.*

#### **II. Background<sup>1</sup>:**

1. *The Environmental Health Specialist's (EHS) primary focus is on good sanitation of equipment and facilities; however, the safety and comfort of the establishment's employees and consumers are considered as well.* The EHS must rely on other code officials and professionals, such as architects and engineers, to provide evidence of compliance with state and local codes related to fire safety, design and installation of exhaust ventilation systems. *All rooms shall have sufficient ventilation to keep them free of excessive heat, steam, vapors, obnoxious odors, smoke and fumes.* Ventilation systems shall be designed and installed according to applicable law. Exhaust hoods shall be *designed to capture and confine cooking vapors and residues and remove them from the establishment.* Exhaust hood systems shall satisfactorily operate during the cooking, dishwashing and other applicable times of operation.

<sup>1</sup> Source: Section 12 – Ventilation – FDA 2008 Plan Review for Food Establishment Guidance Document.

2. *Proper capture and venting of gases, heat, grease, vapors, and smoke generated by cooking equipment is important; for not only fire prevention and sanitation purposes, but for maintaining the health and well being of the establishment's food service employees and consumers. In order to help prevent dangerous or unhealthful conditions within a food service establishment, it is critical that exhaust ventilation systems be designed, constructed, and operated in compliance with all applicable state laws and local codes.*
3. The additional heat and moisture loads generated by *equipment and appliances* shall be accounted for in the design of the HVAC system.

### **III. Fire Protection<sup>2</sup>:**

1. The State's minimum requirements for *Type I commercial kitchen hood ventilation system ducts and exhaust equipment* shall be designed, constructed and installed in accordance with the *Life Safety Code (LSC) NFPA 101 and NFPA 96*<sup>3</sup>. *Other commercial kitchen hood ventilation system ducts and exhaust equipment* shall comply with the requirements of the International Mechanical Code.
2. The State's minimum requirements for fire suppression systems for commercial cooking equipment shall be established by the *Life Safety Code and NFPA 96*. Commercial cooking appliances required to have a Type I hood shall be provided with an approved automatic fire suppression system – *see Illustration Q-11 for example*.

**IV. State or Local Fire Marshall Office<sup>4</sup>:** *Counties with over 100,000 persons and municipalities with over 45,000 persons* are mandated by law to enforce the state's minimum rules and regulations on such buildings in their area of jurisdiction. Resolutions can be submitted by municipalities under 45,000 persons adopting the enforcement responsibilities from the state. *If a county or municipality is not required to conduct enforcement, the State Fire Marshal's Office enforces O.C.G.A. 25-2-14 which lists the facilities under the jurisdiction of the State Fire Marshal's Office.*

### **V. General Principles of Exhaust<sup>5</sup>:**

1. The *purpose of an exhaust hood* is to provide a method of collecting, as nearly as possible, all of the grease produced from the cooking process while furnishing a means of removing heat, smoke and odors from the cooking area. A sufficient volume of air movement (capture velocity) must be provided to effectively draw grease particles and cooking vapors directly from the cooking surface to the grease extractors. This airflow removes cooking odors and keeps grease particles from settling onto nearby surfaces.

---

<sup>2</sup> Source: Table 102.10: Codes Reference Guide – Chapter 120-3-3-.04 State Minimum Fire Safety Standards with Modifications – State of Georgia.

<sup>3</sup> As adopted within Chapter 120-3-3 Georgia State Minimum Fire Safety Standards, this standard provides the minimum fire safety requirements related to the design, installation, operation, inspection, and maintenance of all cooking operations.

<sup>4</sup> Reference: O.C.G.A. 25-2-12 (a) (1) and (b)

<sup>5</sup> Source: Page 12 of Section 12 – Ventilation 2008 FDA Food Establishment Plan Review Guide Document

2. *An effective capture velocity* shall be sufficient to overcome opposing air currents, capture the grease and cooking vapors, and transport them to the grease extractors. When grease vapors cool and condense an extractor removes grease particles by directed airflow, contraction, and expansion (drop out).
3. *For heat and steam producing equipment*, the hood or ventilation system controls humidity, heat and unwanted condensation.
4. *Some equipment may not need mechanical exhaust ventilation*<sup>6</sup>.
  - A. *The following additional criteria* should be taken into consideration when determining the need for mechanical exhaust ventilation:
    - a. Installation of *other unventilated heat generating equipment in the same area*, e.g., refrigeration condensers, steam tables, or counter-top equipment;
    - b. *Presence of heating/cooling (HVAC) system*: Cooking equipment operation temperatures are low enough that the existing room ventilation can compensate for the heat generated by the equipment without creating unsafe or hazardous conditions in the kitchen;
    - c. *Size of the room or area* where the proposed equipment will be installed, including ceiling height;
    - d. *How the proposed equipment will be operated*, e.g., the types of food prepared, how often, etc;
    - e. *Relative size of the proposed equipment*; physical weight, BTU's: Equipment may, due to design or size, cook certain food without producing significant amounts of toxic gases, smoke, grease, vapors, or heat;
    - f. *Nature of the emissions*, e.g., grease, heat, steam, etc;
    - g. Cooking apparatus is *equipped with an air purifying system of baffles, filters, etc. (with or without fire suppression)*, that *effectively removes all toxic gases, smoke, grease, vapors, and heat from the air released by the equipment*; and
    - h. *Method of producing heat*, e.g., gas, electricity, solid fuel, etc.: Cooking equipment that uses solid fuel e.g., wood or charcoal, must be provided with a separate exhaust system.

---

<sup>6</sup>Source: Pages 5 & 6, "Cooking Equipment Exhaust Ventilation Exemption Guide For The Local Enforcement Agency" dated September 2009 published by the California Conference of Directors of Environmental Health and Section 507 in the 2006 International Mechanical Code as adopted by Georgia Department of Community Affairs (DCA)

B. Although following *Listing Q-1* of appliances typically does not require mechanical ventilation, *Listing Q-1 shall not be deemed to supersede any state or local building and fire code requirements*. In addition, *Listing Q-1 does not preclude the local Health Authority and any enforcement agency from requiring the installation of mechanical exhaust ventilation when the operation of the cooking equipment in a specific location may or actually results in a sanitation or safety violation*. Each local Health Authority having jurisdiction will have to evaluate equipment in *Listing Q-1<sup>7</sup>* on a case-by-case basis:

Listing Q-1<sup>8</sup>

- Coffee Equipment:
  - Urn or brewer
  - Roaster (*electric*)
- Corn on the Cob Warmer
- Clam Shell Grill/Panini – (*for heating non-grease producing foods such as tortillas, pastries, rolls, sandwiches from precooked meats and cheeses*)
- Crepe Maker (*no meats*)/Waffle Cone Maker/Waffle Iron
- Hot Dog Warmer - Hot Plate (*electric and induction cooker*) and Roller-Cooker
- Electrical Holding/Warming Ovens and Portable ovens (*light-duty microwave, cook and hold, ovens utilizing visible and infrared light technology*)
- Popcorn Popper (*without external grease vapor release*)
- Rethermalizers (*single light-duty electric*)
- Rice Cookers and Egg Cookers (*electric*)
- Rotisserie (*Electric and enclosed with max. ambient cavity temperature of 250°F*)
- Electrically heated Steam Table
- Toaster – countertop (*bread only*)
- Under-counter-type commercial warewashing machines
- Warewashers and potwashers that are provided with heat and water vapor exhaust systems that are supplied by the appliance manufacturer and are installed in accordance with the manufacturer's instructions

Note: *The additional heat and moisture loads generated by such appliances as those listed above shall be accounted for in the design of the HVAC (Heating, Ventilation and Air-Conditioning) system.*

---

<sup>7</sup> Reference: Section 507.2.2. Type II hoods, Exception #4, Georgia 2006 International Mechanical Code as adopted by the Georgia Department of Community Affairs (DCA) Board as mandated and applicable to Georgia.

<sup>8</sup> Source: Cooking Equipment Exhaust Ventilation Exemption Guide For The Local Enforcement Agency September 2009 as published by the California Conference of Directors of Environmental Health

## **VI. Cooking Equipment Duty Rating Relative to Type of Exhaust Ventilation System:**

### 1. Background<sup>9</sup>:

- A. *Cooking can be described as a process that adds heat to raw or precooked food. As heat is applied to the food, effluent is released into the surrounding environment. This effluent release includes water vapor, organic material released from the food itself, and heat that was not absorbed by the food being cooked. Some forms of reheating, such as rethermalizing limit the effluent released to the space but still emit water vapor to the surrounding space.*
- B. *The hot cooking surface (or fluid, such as oil) and product vapors create thermal air currents (typically called a thermal plume) that are received or captured by the hood and then exhausted. If this thermal plume is not captured and contained by the hood, they become a heat load to the space. The velocity of these thermal plumes depends largely on the surface temperature of the cooking equipment, and varies from 25 feet per minute over some steam equipment, to 200 feet per minute over some char-broilers. Thus, the strength of the thermal plume is a major factor in determining the exhaust rate.*
- C. *Because of the variation in velocity of thermal plumes and the quantity of grease and smoke produced, cooking equipment typically classified in four duty rate categories: light duty (such as ovens, steamers, and small kettles up to 400 °F), medium duty (such as large kettles, ranges, griddles, and fryers up to 400 °F), heavy duty (such as broilers, char-broilers, and woks up to 600 °F) and extra heavy duty (such as solid-fuel-burning equipment - wood, charcoal, etc. - up to 700 °F).*

2. Cooking equipment categorized by duty rate:<sup>10</sup> The following types of cooking equipment are *examples that typically require a Type I or II mechanical exhaust hood ventilation system*. The cooking equipment is divided into extra heavy, heavy, medium and light duty cooking categories. *The following Listings Q-2 through Q-5 are not all inclusive and the requirement of the state or local code requirements supersede these listings:*

---

<sup>9</sup> Source: Heat Load Based Design – Radiant, Convective and Conductive HEAT

<sup>10</sup> Source #1: energy design resources, design brief, Commercial Kitchen Ventilation Design, Southern California Edison – reported source: ASHRAE Standard 154

Source #2: Section 507 - Georgia 2006 International Mechanical Code as adopted by Ga. Dept of Community Affairs

#### Listing Q-2

Extra Heavy Duty Cooking Equipment – associated with a Type I Hood  
*(Appliances using solid fuel such as wood, charcoal, briquettes, and mesquite to provide all or part of the heat source for cooking.)*

- Barbeque
- Charbroiler – *Underfired*
- Tandoor Oven – *(Clay oven mainly used in the preparation of Indian dishes. Other Asian cultures use it as well.)*
- Chinese Range – *(Wok)*

#### Listing Q-3

Heavy Duty Cooking Equipment – associated with a Type I Hood  
*(Cooking appliances that produce grease or smoke)*

- Electric and gas underfired broilers
- Electric and gas chain *(conveyor)*
- Gas open-burner ranges *(with or without oven)*
- Electric and gas wok ranges
- Electric and gas overfired *(upright)* broilers
- Salamanders

#### Listing Q-4

Medium Duty Cooking Equipment – associated with a:  
Type I Hood *(Cooking appliances that produce grease or smoke)* or  
Type II Hood *(Cooking or Warewashing appliances producing heat, steam, or products of combustion and do not produce grease or smoke.)*

- Electric discrete element ranges *(with or without ovens)*
- Electric and gas hot-top ranges
- Electric and gas griddles
- Electric and gas double-sided griddles
- Electric and gas fryers *(including open deep-fat fryers, donut fryers, kettle fryers, and pressure fryers)*
- Electric and gas pasta cookers
- Electric and gas conveyor *(pizza)* ovens
- Electric and gas tilting skillets/braising pans
- Electric and gas rotisseries

Listing Q-5

Light Duty Cooking Equipment – associated with a:  
Type I Hood (*Cooking appliances that produce grease or smoke*) or  
Type II Hood (*Cooking or Warewashing appliances producing heat, steam, or products of combustion and do not produce grease or smoke.*)

- Gas and electric ovens (*including standard, bake, roasting, revolving, retherm, convection, combination convection/steamer, conveyor, deck or deck-style pizza, and pastry*)
- Electric and gas steam-jacketed kettles
- Electric and gas compartment steamers (*both pressure and atmospheric*)
- Electric and gas cheesemelters
- Electric and gas rethermalizers

**VI. Types of Hoods:**

1. *A Type I or Type II hood shall be installed at or above all commercial cooking appliances in accordance with the International Mechanical Code and or International Fire Code. Where any cooking appliance under a single hood requires a Type I, a Type I hood shall be installed. Where a Type II hood is required, a Type I or Type II shall be installed<sup>11</sup>.*
2. *A hood shall be designed to provide thorough cleaning of the entire hood. Grease gutters shall drain to an approved collection receptacle that is fabricated, designed and installed to allow access for cleaning. Exhaust ventilation hoods and devices shall be designed and installed to prevent grease or condensation from collecting on walls, ceilings, and fire suppression supply piping and from dripping into food or onto food contact surfaces<sup>12</sup>.*
3. Type I Hoods<sup>13</sup>:
  - A. *Type I hood systems are installed where cooking appliances produce grease or smoke, such as occurs with griddles, fryers, broilers, ovens, ranges and wok ranges.*

*Type I hood systems shall be designed and installed to automatically activate the exhaust fan whenever cooking operations occur. The activation of the exhaust fan shall occur through an interlock with the cooking appliances, by means of heat sensors or by other approved means.*

---

<sup>11</sup> Source: 507.2 Where required – Section 507 Commercial Kitchen Hoods – GA 2006 International Mechanical Code as adopted by the Georgia Dept. of Community Affairs.

<sup>12</sup> Source: 507.8 Cleaning and grease gutters - Section 507 Commercial Kitchen Hoods – GA 2006 International Mechanical Code as adopted by the Georgia Dept. of Community Affairs.

<sup>13</sup> Source: 507.2.1 Type I hoods & 507.2.1.1 Operation - Section 507 Commercial Kitchen Hoods – GA 2006 International Mechanical Code as adopted by the Georgia Dept. of Community Affairs.

- B. A Type I hood shall be installed with a clearance to combustibles of not less than 18 inches. Clearance is not required for gypsum wallboard attached to noncombustible structures if a smooth, cleanable, nonabsorbent and noncombustible material is installed between the hood and the gypsum wallboard over an area extending not less than 18 inches in all directions<sup>14</sup>.

4. Type II Hoods<sup>15</sup>:

- A. *Type II Hood Systems are installed where cooking or dishwashing appliances produce heat, steam, or products of combustion and do not produce grease or smoke, such as steamers, kettles, pasta cookers and dishwashing machines.*
- B. *Exceptions include under-counter-type commercial dishwashing machines; dishwashers and potwashers that are provided with heat and water vapor exhaust systems that are supplied by the appliance manufacturer and installed in accordance with the manufacturer's instructions; single light-duty electric convection, bread retherm or microwave oven; and electrically heated appliances: toasters, steam tables, popcorn poppers, hot dog cookers, coffee makers, rice cookers and holding/warming ovens.*
- C. *See Illustrations Q-1, Q-8, Q-9 and Q-12 for examples of a Type II Hood system.*

**VIII. Make-Up Air**<sup>16</sup>:

- 1. *Make up air shall be supplied during the operation of commercial kitchen exhaust systems that are provided for commercial cooking appliances. The amount of makeup air supplied shall be approximately equal to the amount of exhaust air. Makeup air shall be provided by gravity or mechanical means or both.*
- 2. *If make-up air were not provided, the building would be under a negative pressure, which could cause the following serious problems:*
  - A. *The exhaust fan would not be capable of exhausting the design volume of air because the air would not be available.*
  - B. *Negative pressure would cause improper venting of water heaters, space heaters, or the individually vented gas appliances in the establishment.*
  - C. *A negative pressure will cause a surge of unconditioned outside air into the building whenever the doors are opened, which may also allow the entrance of flies into the establishment.*

---

<sup>14</sup> Source: 507.9 Clearances for Type I hood - Section 507 Commercial Kitchen Hoods – GA 2006 International Mechanical Code as adopted by the Georgia Dept. of Community Affairs.

<sup>15</sup> Source: 507.2.2 Type II hoods - Section 507 Commercial Kitchen Hoods – GA 2006 International Mechanical Code as adopted by the Georgia Dept. of Community Affairs.

<sup>16</sup> Source: 508 Commercial Kitchen Makeup Air – GA 2006 International Mechanical Code as adopted by the Georgia Dept. of Community Affairs.



4. *For a consistent and regulated flow, make-up air should be mechanically introduced by a fan or gravity. Outside windows and doors shall not be used for the purpose of providing make-up air. Air conditioning systems may also serve as a source of make-up air,*
5. *Make-up air controls should be interlocked with exhaust controls to ensure that the units operate simultaneously. Replacement air shall be filtered and may also be tempered by a separate control. The air velocity through the make-up air system should be low enough to avoid the possibility of drafts. It is desirable to have the kitchen under a very slight negative pressure to prevent any filtration of cooking odors from the kitchen into the dining room. The supply of make-up air is frequently introduced at some point in close proximity to the hood to avoid the removal of conditioned air that has been heated or cooled.*
6. *The State's minimum requirements for commercial kitchen makeup air in Type I hoods shall be in accordance with the Life Safety Code, NFPA 101<sup>17</sup> and NFPA 96<sup>18</sup>. Commercial kitchen makeup air for Type II hoods shall comply with the requirements of the International Mechanical Code.*

**IX. Noncanopy and Canopy Size and Location<sup>19</sup>:**

1. Canopy:
  - A. *The inside lower edge of canopy-type I and II hood shall overhang or extend a horizontal distance of not less than 6 inches beyond the edge of the top horizontal surface of the appliance on all open sides. The vertical distance between the front lower lip of the hood and the cooking surface shall not exceed 4 feet. The hood shall be permitted to be flush with the outer edge of the cooking surface where the hood is closed to the appliance side by a non-combustible wall or panel.*
  - B. *Canopy hoods both wall and island should have a minimum depth of two feet. No overhang will be required on sides where aprons are installed; however, side overhang shall be required when less than full side curtains are provided (Illustration Q-2). The dimensions of the hood are, in all cases, larger than the cooking surface to be covered by the hood.*
  - C. *Canopy hoods are generally installed so that the bottom of the hood is between 6.5 feet and 7 feet above the finished floor (Illustration Q-3.); however, the vertical distance between the lower lip of the hood and the cooking surface shall not exceed 4 feet.*

---

<sup>17</sup> National Fire Protection Association - Life Safety Code

<sup>18</sup> National Fire Protection Association – Standard for the Ventilation Control and Fire Protection of Commercial Cooking Operations

<sup>19</sup> Source: 507.12 Canopy size and location & 507.14 Noncanopy size and location – Section 507 – GA. 2006 International Mechanical Code as adopted by the Georgia Department of Community Affairs.

- D. In some applications, the minimum six-inch overhang may not be sufficient to capture all of the smoke, vapors, or grease generated by the cooking equipment. *A 12–18-inch overhang is recommended for large or stacked ovens, conventional steamers, large tilting kettles, and bain-maries.* An overhang at the side of the hood is also recommended for char broilers when the equipment is *located at the end of the cook line.*
- E. *See Illustration Q-12* for additional examples of canopy hoods.
2. Non-canopy:
- A. *Non-canopy type hoods* shall be located a *maximum of 3 feet above the cooking surface.* The edge of the hood shall *be set back a maximum of 1 foot from the edge of the surface.*
- B. Ventilator or Backshelf Hood: *Backshelf hoods are designed to mount to the wall directly behind the cooking equipment.* This type of hood is often *used where ceiling height is a factor.* It is normally placed closer to the cooking surfaces than a canopy hood, and works well in light to medium duty cooking applications. The ventilator hood is not used for char broilers or similar high heat and grease producing cooking equipment. *It does not have the capture area of a canopy hood and is not able to effectively handle large surges of cooking emissions (steam, heat, vapors, smoke etc.) See Illustration Q-4 and Illustration Q-12 for example.*
- C. Eye-Brow Hoods:
- a. *Eye-brow hoods* are acceptable for use with either Type I or Type II hoods. The eye-brow hood shall overhang, or extend a horizontal *distance of at least six inches, beyond all areas of the equipment out of which steam, grease, odors, smoke, or heat will be emitted – see Illustrations Q-5 and Q-6.*
- b. An eyebrow hood is *designed to immediately remove heat from the oven at the point of emission or as the door is opened.* It must effectively ventilate the door openings or product entry/exit points of the equipment served.
- c. The eyebrow-type oven hood *shall be located above the product transfer openings or doors and shall extend the width of the oven-baking cavity.* An eyebrow-type hood shall be of a rectangular or box type construction with a *recommended minimum of 12 inches of front overhang.*
- d. *Filters shall be provided* and they shall be easily accessible for cleaning.
- e. *When the width of the product transfer openings or doors is less than the width of the oven-baking cavity,* the hood shall be designed to extend beyond the edge of the product transfer openings or doors a *minimum distance of 3 inches but not to extend beyond the width of the oven.*

D. Waterwash Exhaust Hoods:

- a. *Waterwash hoods* operate under the following principles. As the exhausted air moves at a high velocity past a baffle system, the heavier-than-air particles of grease are thrown out of the airstream by centrifugal force. The extracted grease is collected in grease gutters within the hood until removed by the daily cleaning cycle. The cleaning cycle is initiated when the exhaust hood is turned off. Hot detergent water is automatically sprayed onto the baffles system, thereby removing the grease deposits from the baffles. This wastewater is then drained off to the sewer or other approved waste removal system.
- b. *In order to protect the potable water supply*, an approved backflow prevention device, such as a reduced pressure principle device, is required to be installed on the water inlet pipe, prior to the detergent pump solenoid.
- c. The wastewater from a water-wash-type hood shall be drained through an air gap separation into an approved receptacle, such as a floor sink. (*See Illustration Q-7 Waterwash Hood*).

E. Recirculating Hood Systems (Ductless hoods or Ventless hoods)<sup>20,21</sup>:

- a. Where it is not possible to exhaust the air to the out-of-doors and *at the discretion of the code official and or health authority*, a non-ducted, self-contained exhaust system may be a viable option for the food establishment.
- b. These devices incorporate an air filtering system enclosed in a hooded or otherwise contained area intended to capture air from the cooking process area. The hood assembly generally includes a fan, collection hood, or equivalent design feature, air filtering system (consisting of a grease filter with other filters), a fire actuated damper, and a fire extinguishing system unit.
- c. *Manufacturer of recirculation hood systems must furnish documentation indicating their products full compliance with all Georgia laws and local codes*. Further, said documentation *must insure the effective removal* of excessive smoke, grease, obnoxious odors, condensation, vapors and fumes generated by cooking equipment.
- d. *UL 710B requirements* cover commercial electric cooking appliances provided with integral recirculating systems (previously referred to as ductless hoods) and nonintegral recirculating systems, both of which are intended for installation in commercial establishments for the preparation of food.

---

<sup>20</sup> Source: Cooking Equipment Exhaust Ventilation Exemption Guide For The Local Enforcement Agency as published by the California Conference of Directors of Environmental Health.

<sup>21</sup> Source: 507.1 General – Exceptions – Section 507 Commercial Kitchen Hoods – GA 2006 International Mechanical Code as adopted by the Georgia Department of Community Affairs.

- e. *The cooking equipment and exhaust system shall be interlocked such that when the hood is not functional or when the hood is operating at less than 85% efficiency, the cooking equipment will not operate.*
- f. *If a water-wash system is incorporated into the design, an approved backflow prevention device shall be installed when potable water is plumbed to the hood system, e.g., on the water inlet pipe, prior to the water pump solenoid. The wastewater from the scrubbing operation shall be drained through an air gap separation into an approved receptacle, such as a floor sink.*
- g. *Since a nonducted exhaust system does not normally remove the heat from the exhausted air, the establishment's HAVC system and the nonducted exhaust system must be engineered to balance the establishment's HAVC system. Additional air conditioning will be required to meet the increase BTUs being returned to the room in addition to other heat generating equipment. Due to this increased air handling capacity demand of HAVC with nonducted exhaust system characteristic, nonducted exhaust systems are considered equipment and facility specific and as such, they and the HAVC system both must be engineered and installed to the specific ventilation requirements of the proposed food service facility.*
- h. *All filters, etc., must be readily removable for ease of maintenance.*
- i. *The design nonducted exhaust hoods must be such that grease and condensate cannot drip back onto the cooking surfaces.*
- j. *See Illustration Q-13 for examples of Ventless Hoods.*

**X. Dishwashing Appliances:**

- 1. *A Type II Hood is not required for dishwashers and potwashers provided with heat and water vapor exhaust systems that are supplied by the appliance manufacturer and installed in accordance with their instructions. See Illustration Q-8 Pants Leg Exhaust System in Section Q of Part I within the online Food Service Manual for Design, Installation and Construction for an example of a typical installation.*
- 2. *The top and side of the vestibule shall extend 10 inches horizontally over the drainboard on each end of the warewashing machine. The design shall prevent drippage from the hood and duct onto utensils and equipment. The machine manufacturer's recommended air quantities (Q) shall be used or the following:*
  - A. *500 cfm minimum on single rack (or manufacturer's recommendations).  
30% (150) cfm at entrance – 70% (350) cfm at exit.*
  - B. *600 cfm minimum for conveyor (or manufacturer's recommendations).  
30% (180) cfm at entrance – 70% (420) cfm at exit.*

- C. 1200 cfm minimum on flight type (or manufacturer's recommendations).  
30% (360) cfm at entrance – 70% (840) cfm at exit.

*Note: cfm = Cubic Feet per Minute.*

3. Ductwork with reduced area or fixed control damper may be used on entrance.
4. *The minimum net air-flow for Type II Hoods used for dishwashing appliances shall be 100 CFM per linear foot of hood length<sup>22</sup>. See Illustration Q-9 within Section Q-Ventilation of Part I within the online Food Service Manual for Design, Installation and Construction for an example of a typical installation.*

#### **XI. Grease Filters<sup>23</sup>:**

1. *Grease filters for type I hoods shall be equipped with listed grease filters designed for the specific purpose. Grease collecting equipment shall be provided with access for cleaning.*
2. *Filters shall be of such size, type and arrangement that will permit the required quantity of air to pass through such units at rates not exceeding those for which the filter or unit was designed or approved. Filter units shall be installed in frames or holders so as to be easily removable without the use of separate tools, unless designed and installed to be cleaned in place and the system is equipped for such cleaning in place.*
3. *Removable filter units shall be of a size that will allow them to be cleaned in a dishwashing machine or pot sink. Filter units shall be arranged in place or provided with drip-intercepting devices to prevent grease or other condensate from dripping in food or on food preparation surfaces.*
4. *Filters shall be installed at an angle of not less than 45 degrees for the horizontal and shall be equipped with a drip tray beneath the lower edge of the filters<sup>24</sup>. See Illustration Q-10.*
5. Grease Filter Area and Number of Grease Filters Required<sup>25</sup>:
  - A. *The extractor filter removes grease in the exhaust process by centrifugal motion or by impingement on a series of baffles. The manufacturer's optimum rating of the filter should be used in calculating the filter area required in the exhaust system. Standard size filters should be used to avoid additional cost and to allow ease of replacement. Any space in the filter bank not covered by filters/extractors shall be fitted with sheet*

---

<sup>22</sup> Source: 507.13.5 Dishwashing appliances – Section 507 Commercial Kitchen Hoods – 2006 International Mechanical Code as adopted by the Georgia Depart. of Community Affairs.

<sup>23</sup> Source: 507.11.1 Criteria - Section 507 Commercial Kitchen Hoods – 2006 International Mechanical Code as adopted by the Georgia Depart. of Community Affairs.

<sup>24</sup> Source: 507.11.2 Mounting position – Section 507 Commercial Kitchen Hoods - 2006 International Mechanical Code as adopted by the Georgia Depart. of Community Affairs.

<sup>25</sup> Reference: Section III, Part 15-Ventilation, 2000 FDA Food Establishment Plan Review Guide

---

---

metal blanks. *If calculations indicate that a fraction of a filter is needed, add an additional filter.*

- B. The filter area required for an exhaust system can be calculated by using the following formula:

- a. Formulas:

$$\frac{\text{Volume of Air Exhausted}}{\text{Operating Velocity of Filter (FPM)}} = \text{Filter Area Needed (sq. ft.)}$$

$$\frac{\text{Filter Area Needed (sq. ft.)}}{\text{Square Feet per Filter}} = \text{Number of Filters Needed}$$

$$\frac{\text{Square Inches}}{144 \text{ sq. in per sq. ft.}} = \text{Square Feet}$$

- C. Assume we have a canopy hood with a minimum required airflow of 4250 CFM. The hood will be equipped with baffle-type filters with a nominal size of 16 inches x 20 inches and they will have an actual filtering surface of 14 inches x 18 inches. (Nominal size minus the frame equals the actual filtering area.) The optimum operating velocity of the stated filters is 360 FPM. How many 16”x 20” filters would be necessary for the canopy hood system?

- b. Calculations:

Step 1. Determine filter Area Needed in Square Feet:

$$\frac{4250 \text{ CFM}}{360 \text{ FPM}} = 12 \text{ sq.ft.}$$

Step 2. Covert the actual filter area to square feet:

$$14 \text{ in.} \times 18 \text{ in.} = 252 \text{ sq. in.}$$

$$\frac{252 \text{ sq. in.}}{144 \text{ sq.in. per sq. ft.}} = 1.75 \text{ sq.ft.}$$

Step 3. Divide the 12 sq.ft. of needed filter area by sq.ft. per filter:

$$\frac{12 \text{ sq.ft.}}{1.75 \text{ sq.ft.}} = 6.85 \text{ or } \underline{7 \text{ filters}}$$

- c. Results: In this example, 7 baffle filters would be required to adequately remove grease from the exhausted air.

## **XII. Capacity of Hoods:**

1. Commercial food service hoods shall exhaust a minimum net quantity of air as determined by the type of hood and cooking appliances. *Where any combination of heavy-duty, medium-duty and light-duty cooking appliances are utilized under a single hood, the exhaust rate required for the heaviest duty appliance covered by the hood shall be used for the entire hood.*
2. Extra heavy, heavy and medium cooking appliances *must use a Type I* ventilation exhaust hood system. Light duty cooking appliances *may use a Type I or Type II* ventilation exhaust hood system.
3. *The amount of air exhausted through a hood exhaust system is dependent upon the size of the hood, its particular installation, and its use.* There are several methods available for determining the amount of air to be exhausted. With the exception of systems engineered for specific equipment and specifications that are approved by local code officials and or the Health Authority. Below is a summary of the method generally accepted in the industry; however, the method approved by the local codes should be followed in the design of the system:
  - A. *Exposed linear foot method.* This method of calculating the exhaust air volume is based on the total exposed linear footage of the hood and the capture velocity relative to its application
  - B. *Standard square foot method.* This method of calculating exhaust air volume is based on the size of the opening in the hood (length x width) and the capture velocity relative to the installation of the hood
  - C. *Square feet of cooking surface method.* This calculation of the volume of exhausted air depends on the size, temperature, and design of the cooking equipment and the minimal capture velocity required to keep smoke, vapors, and fumes under the hood.
4. *The International Mechanical Code uses the exposed linear foot method for calculating the minimum net airflow based on hood type and category of cooking appliance. Table Q-1 has the minimum air volumes that shall be used to calculate the amount of air exhausted for hood system and cooking category.*

**TABLE Q-1<sup>26</sup>**

*Minimum Net Airflow (cubic feet per minute / linear foot of hood length) based on the Type of Hood Allowed and Cooking Appliances Category*

\* Light duty cooking appliances can use Type 1 or Type II hoods. All other categories use Type I hoods.

Type of Hood/ Use Category	Backshelf/pass-over	Double island canopy per side	Eyebrow	Single island canopy	Wall-mounted canopy
<b>Extra Heavy Duty</b>	Not allowed	550	Not allowed	700	550
<b>Heavy Duty</b>	300	300	250	500	300
<b>Medium Duty</b>	400	400	Not Allowed	600	400
<b>Light Duty*</b>	250	250	250	400	200

5. Exposed Linear Foot Method Exhaust Ventilation Hood System Sample Calculation:

- A. Example: *Extra Heavy Duty Equipment* is covered by 12 feet by 4 feet single island canopy hood. Use the preceding information and tables to determine the following:
- B. If the cooking equipment is extra heavy duty, we are required to use a Type 1 canopy hood, either, double-island, wall-mounted or single. A ventilator/backshelf/pass-over or eyebrow hood is not allowed to be used over extra heavy-duty appliances. The calculations use a standard volume of air per linear foot of exposed side of hood. The air volume is based on the type of hood (i.e. three side canopy, wall-mounted canopy) and type of appliance.
  - a. Select the proper category for the cooking appliance (extra-heavy, heavy, medium or light). Deep fat fryers are considered extra heavy-duty cooking appliances.
  - b. Select the appropriate type of hood for the category of cooking appliance (wall mounted, three sided, etc.). *Table Q-1* lists the type of hoods that can be used for extra heavy-duty cooking appliances. For this example, we are using a single island canopy.

<sup>26</sup> Source: 507.13.1, 507.13.2, 507.13.3 – Section 507 Commercial Kitchen Hoods – 2006 International Mechanical Code as adopted by the Georgia Dept. of Community Affairs.



- i. *Step 1. Find the total linear feet of hood:* there are 4 exposed sides on a single island canopy.

*Total linear feet of hood = (2 length + 2 width)*

Example: (2 x 12 feet) + (2 x 4 feet) = 32 linear feet of hood

- ii. *Step 2. Select the net airflow volume* for a single canopy hood used over an extra heavy-duty cooking appliance.

*See Table 1. Single Island Canopy used over Extra Heavy Duty Appliance*

Example = 700 cfm per linear foot of hood

- iii. *Step 3. Use Formula for Airflow:*

*Minimum Net Airflow = linear feet of hood x net airflow per linear foot of hood*

Example Results:

32 feet of linear hood x 700 cfm per linear foot of hood = 22, 400 cfm

- c. *The net quantity of exhaust air shall be calculated by subtracting any airflow supplied directly to a hood cavity from the total exhaust flow rate of a hood.*

### **XIII. Installation and Performance Testing<sup>27</sup>:**

1. *Prior to the issuance of a food service permit, the permit applicant shall provide documentation to the Health Authority verifying that his or her ventilation system(s) serving food service equipment have been installed correctly; have been tested and operating properly as per applicable Codes; and that it has been approved by applicable State and or local code officials.*

---

<sup>27</sup> Source: 507.16 Performance test - Section 507 Commercial Kitchen Hoods – 2006 International Mechanical Code as adopted by the Georgia Depart. of Community Affairs.

**IX. Exhaust Equipment:**

**ILLUSTRATION Q-1**

*Dishwasher with Heat and Water Vapor Exhaust System*



*This Type II Hood system is called a Pans Leg Hood due to the two duck work located at the entrance and exit of the warewashing machine looks like the legs of a pair of pants.*

**ILLUSTRATION Q-2**

*Canopy Hood with Side*

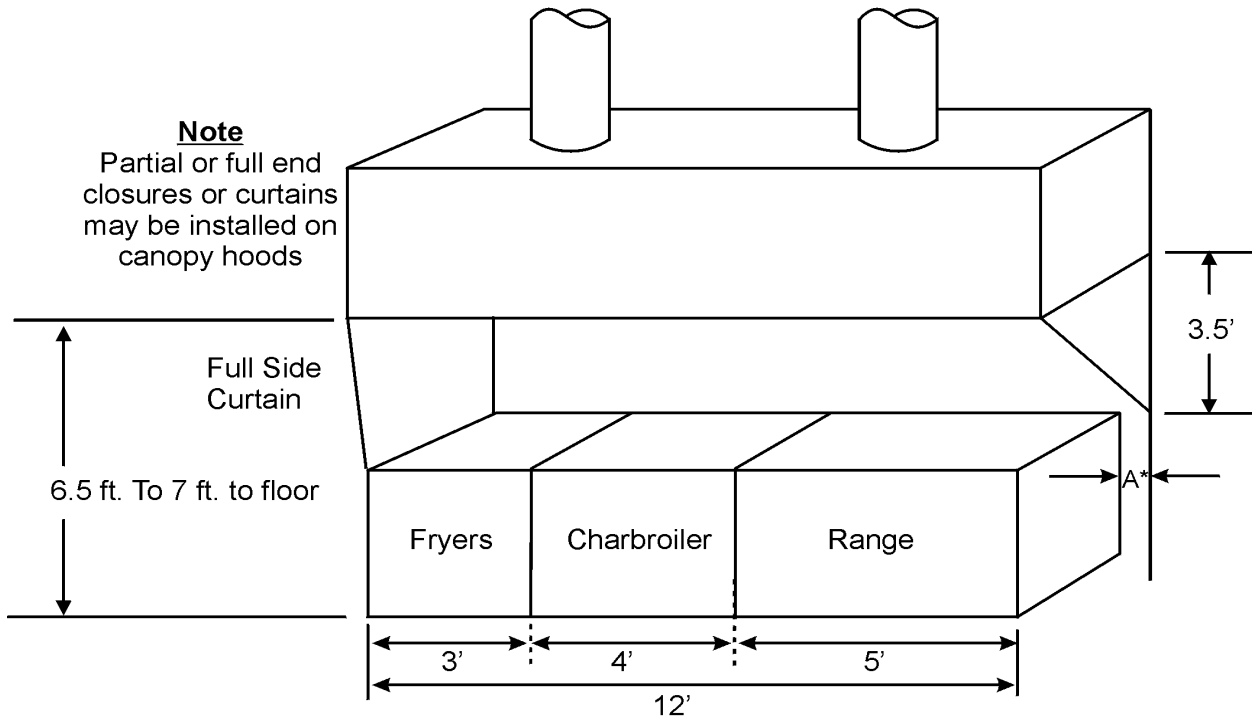

A\* - Required overhang for side curtains less than full

**ILLUSTRATION Q-3**

*Canopy Hoods*

TYPICAL DESIGN PRINTS AND  
 DIAGRAMS FOR CANOPY HOODS

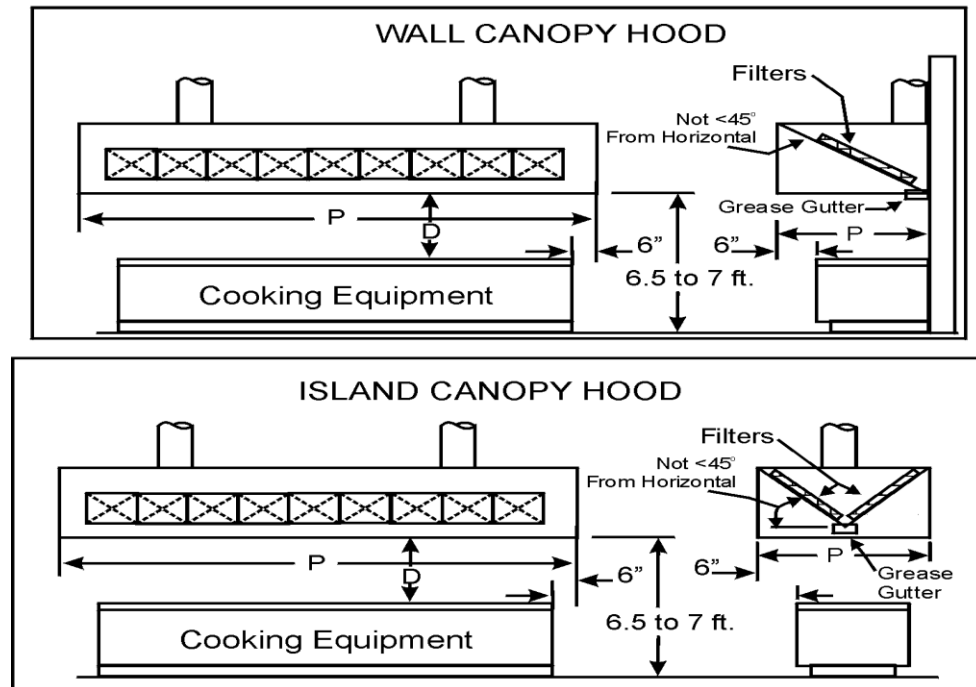

*P = Length & Width of Hood; D = Distance from Cooking Surface*



*Canopy Hood Over Pizza Ovens*



*Island Hood Installed Over Cook Line*

- *The overhang of the hood depends on the distance between the top of the cooking surface and the hood.*
- *Six inches is the minimum required overhang for canopy hoods*
- *The higher the hood is hung above six feet six inches the more overhang you should have.*
- *Canopy hoods must be installed so that the bottom of the hood is between 6.5 feet and 7 feet above the finished floor.*

**ILLUSTRATION Q-4**  
*Backshelf Exhaust Hood*

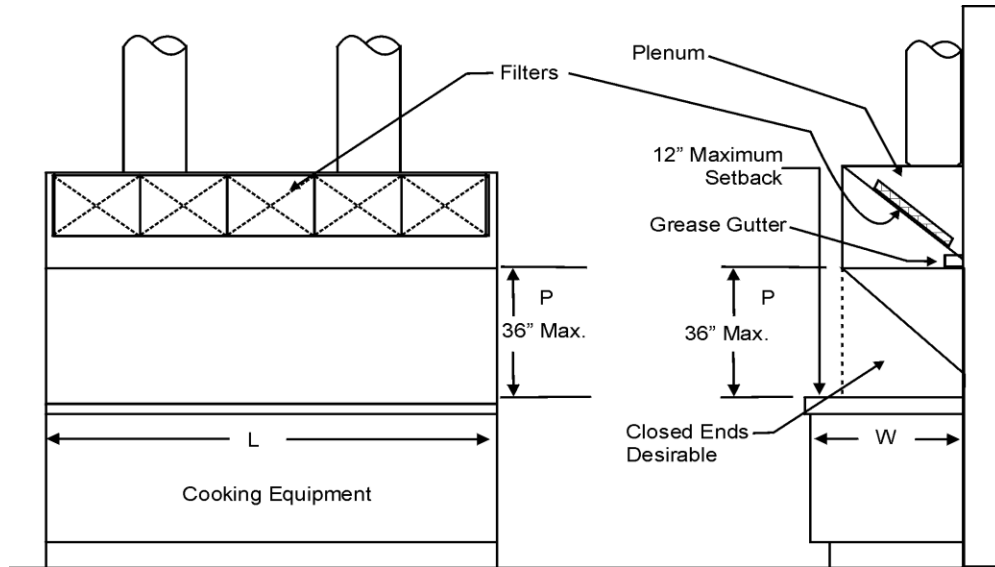

P = Height from Cooking Surface to Exhaust Hood  
 L = Length of Cooking Surface (Combined Cooking Equipment Surfaces)  
 W = Depth of Cooking Surface



*Backshelf Hood*



- Use where ceiling height is a factor
- Normally placed closer to cooking surface than a canopy hood
- Works well in light to medium duty applications
- Not recommended for charbroilers or woks or similar high heat and grease producing equipment. (Does not have capture area of a canopy hood.)
- Cannot use with cheesemelters, salamanders, upright ovens, or tandoori ovens.

**ILLUSTRATION Q-5**  
*Eye Brow Hood on a Pizza Oven*

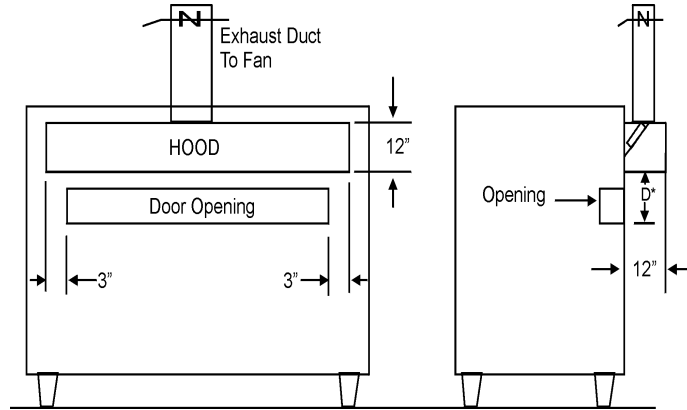

*Eye Brow Hood Over Ovens*



**ILLUSTRATION Q-6**  
*Eye Brow Hood on a Conveyor Oven*

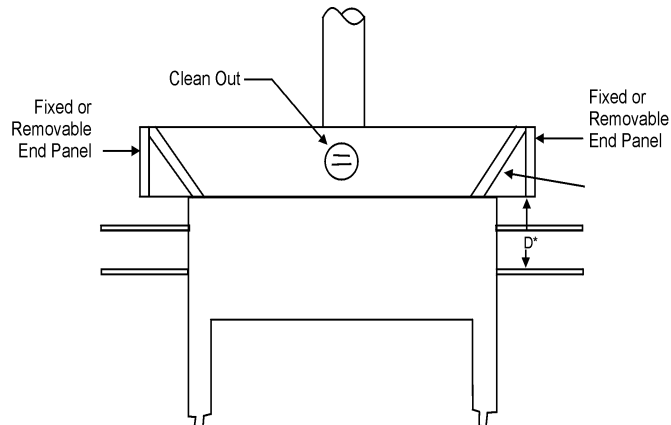

**ILLUSTRATION Q-7**  
*Waterwash Exhaust Hoods*



*The open cabinet of the above self-cleaning (or Waterwash Hood) ventilation hood reveals the automatic cleaning unit apparatus. Notice the cleaning agent in the visible jug that is connected to the cleaning unit. Instructions on how to operate the self-cleaning unit are located in the pouch on the cabinet door.*



*Some waterwash hoods can be built with removable filters; however, most have fixed filters.*

**ILLUSTRATION Q-8**  
*Pant Legs Exhaust*

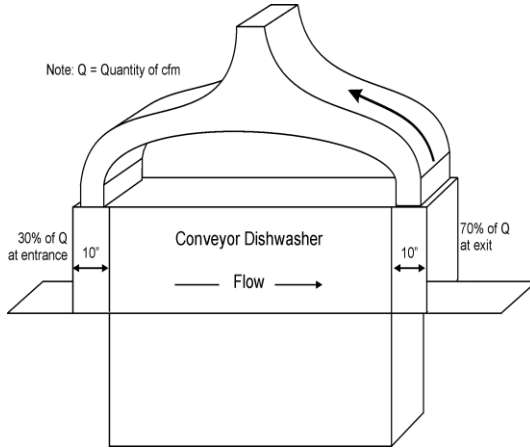

**ILLUSTRATION Q-9**  
*Typical Installation of a Canopy Hood over Warewashing Machine*

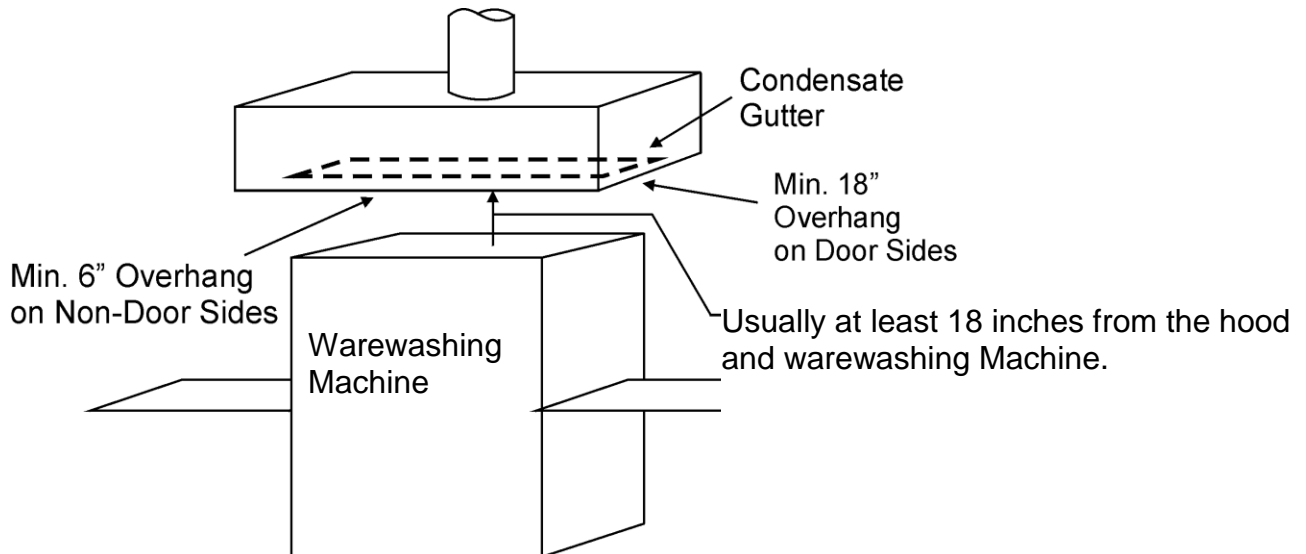

**ILLUSTRATION Q-10**  
*Grease Filter Placement*

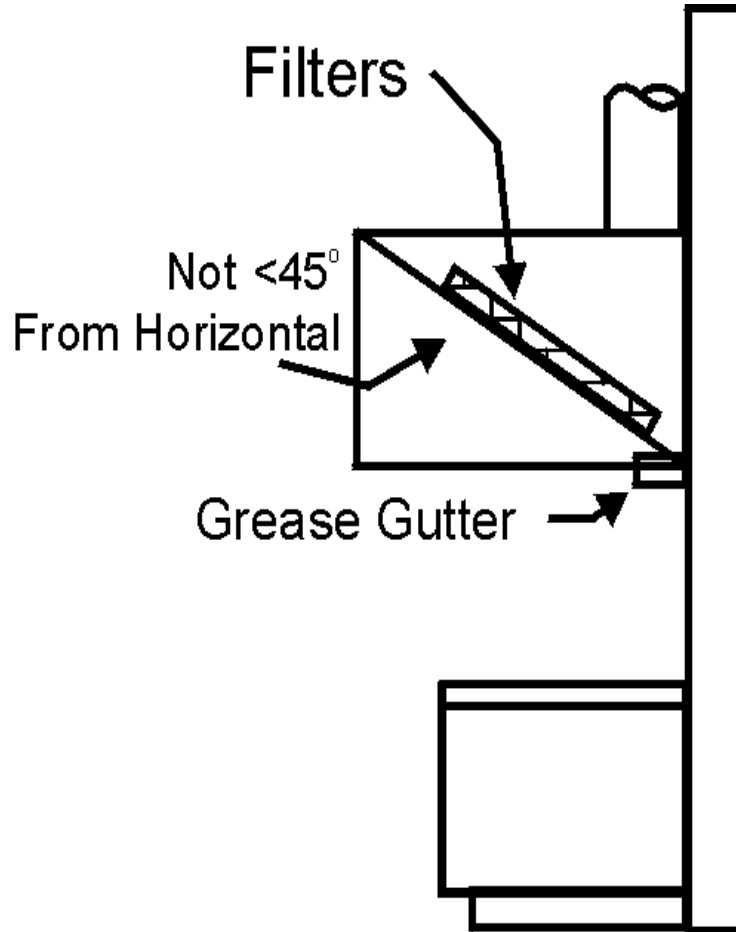



**ILLUSTRATION Q-11**  
*Example of Automatic Fire Suppression Systems<sup>28</sup>*



*Exhaust ventilation systems for all grease producing cooking equipment is the jurisdiction of the state or local Fire Marshal and building officials. The plan Reviewer should refer applicant to the appropriate agency.*

---

<sup>28</sup> Source: Automatic Fire Suppression System borrowed from: Greenheck Building Value in Air, Schofield, WI and from the current 2008 FDA Plan Review Training Course #FD207 presentation materials.

**ILLUSTRATION Q-12<sup>29</sup>**

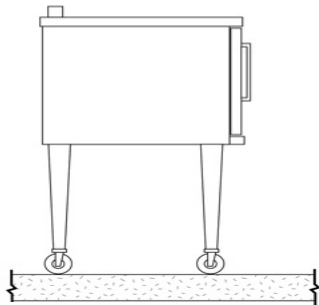
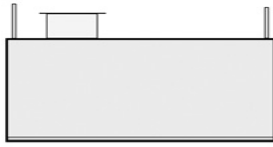

*Island Canopy Hood*

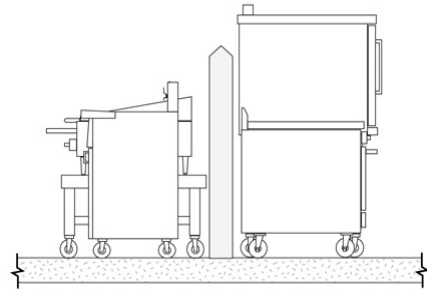
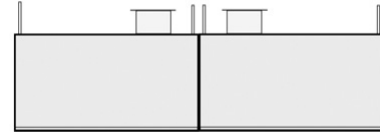

*Double-Island Canopy Hood*

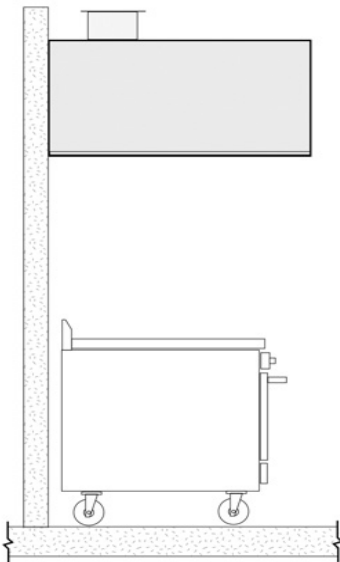

*Wall-Mounted Canopy Hood*

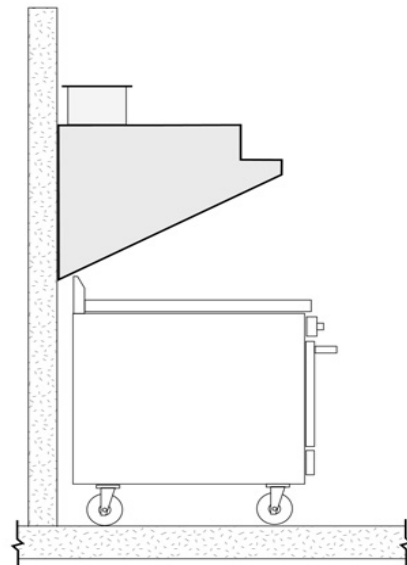

*Proximity (Backshelf) Hood*

<sup>29</sup> Source: design brief Commercial Kitchen Ventilation Design, Architectural Energy Corporation, Boulder, Colorado, and Fisher Nickel Inc., San Ramon, California under auspices of the California Public Utilities Commission.

**ILLUSTRATION Q-13**  
*Examples of Ventless Hood Systems*



*Ventless hoods are somewhat controversial. There are certain applications where they may be appropriate. In situations where a grease duct cannot go up to a roof due to living quarters above or cannot utilize a side discharge through a wall, they may be appropriate. Routine maintenance has been a common problem. Also, without a well designed HVAC system, heat dispersal is a problem. The local Health Authority must evaluate these type exhaust hood systems on a case-by-case basis.*