

The Symphony[®] Breastpump

Maintenance & Technical Guide



Table of Contents

Save These Instructions	1
Symphony® Technical Description	2
Symphony® Breastpump Controls & Parts	3
<i>Symphony Diagram.....</i>	<i>3</i>
<i>Symphony Kit Diagram</i>	<i>3</i>
Visual & Functionality Checklist.....	4
Vacuum Check.....	5
Recommendations for Replacement	6
How to Check Pump Total Running Hours	7
Error Codes.....	8-9
Battery Care & Maintenance	10-11
Inspect & Replace Diaphragms.....	12-13
Low or No Suction.....	14-15
Trolley Repair	16-17
No Power.....	18-19
Reseating Cover	20-21
Replace and Load Program Card	22-23
Proper Use of Vacuum Gauge	24-25
Inspect & Replace Power Cord	26-27
Correct Separated Housing.....	28-29
Cleaning	30-31
Terms of Guarantee.....	32

Save These Instructions

The Medela® Symphony® Breastpump has been specially developed to meet the most stringent demands where hygiene and mobility are concerned. The operating principle of the Medela Symphony is to simulate the natural, physiological conditions encountered in breastfeeding.

The pump's kit is separate from the pumping mechanism and protected from overflow by a specially designed membrane. Kit components which could come in contact with the milk are part of the accessories and can be very easily disconnected for cleaning and sterilization.

A carrying case is available, offering ample space for the pump and the accessory kit.

There are two different models of Symphony with the following general specifications:

Symphony Breastpump, article no. 0240108

- one knob control for both vacuum and suction cycles
- powered by regular electric outlet (100-240 VAC)

Symphony Breastpump Plus, article no. 0240208

*same as above (0240108), but with 2 internal rechargeable 6 volt batteries

Both models can be used for single and for double pumping by using the appropriate accessory kit. Refer to the separate accessory kit user's instructions for further details.

IMPORTANT SAFEGUARDS

WARNING: To reduce the risk of burns, electrocution, fire, or injury to persons:

1. Separation from the power outlet is only assured through the disconnection of the plug and socket connection.
2. This equipment is not suitable for use in the presence of a flammable anesthetic mixture.
3. Use only in a dust-free environment.
4. Do not place in or drop motor unit into water or other liquid.
5. Do not reach for any electrical device if it has fallen into water. Unplug immediately.
6. Never operate an electrical device if it has a damaged cord or plug, if it is not working properly, if it has been dropped or damaged, or if it has been dropped into water.
7. Only use the electric cord that comes with the Symphony Breastpump.
8. Make sure the voltage of the device is compatible with the power source.

Symphony® Technical Description

Safety Instructions



Medical Equipment
With Respect to Electrical Shock, Fire and Mechanical Hazards Only
In Accordance With IEC 60601 -1 CAN/CSA 22.2 No. 601.1 22PL

Protection class II



(Double Insulation)



Follow Instructions



Type B



Alternating Current



Direct Current

Vacuum:

-50mmHg – -250mmHg
-7kPa – -33kPa

Power Supply:

Conventional Outlet:

100V - 240VAC
50/60 Hz
0.5 A

DC Connection:

12 VDC
25 W
T=2,5A



Use only with
Medela® Vehicle Lighter
Adapter #67173

Battery:

2 x 6 V, 1.2 Ah Type: Yuasa NP 1.2-6
Battery(optional): Battery, DC powered
Charging time=12 hours
Full battery pumping
time=approx. 60 minutes



ESD—Use ESD protection when servicing pump.

Disposal:

This breastpump is made of technical plastics and metals that cannot be separated. It must be disposed of in accordance with local regulations.

Warranty: 3-years for the unit from the date of delivery, excluding pump set and batteries. The manufacturer is not liable for any damage or consequential damage caused by incorrect operation, inappropriate usage or use by unauthorized persons. Routine checks, servicing and battery exchange may only be carried out by Medela authorized personnel.

Dimensions :

	With Stand	Without Stand
Length	16.1"	8.5"
Width	16.1"	6.1"
Height	35.4"	9.6"

Weight:

With Battery: 6 lbs. 7 oz.
Without Battery: 5 lbs. 1 oz.

Environmental Conditions for Operation:

Temperature: +41°F to +104°F
Relative Humidity: 20% to 80%
Atmospheric Pressure: 70 kPa to 106 kPa

Environmental Conditions

Transport and Storage:

Temperature: -4°F to +122°F
Relative Humidity: 20% to 95%
Atmospheric Pressure: 70 kPa to 106 kPa

Standards:

FDA (GMP)
ISO 9001
ISO 13485
CE (93/42/EEC)

Electromagnetic or Other Interference:

Complies with IEC 60601-1-2. Unlikely to interfere with other electrical equipment.

Symphony® Breastpump Controls & Parts

Symphony Diagram

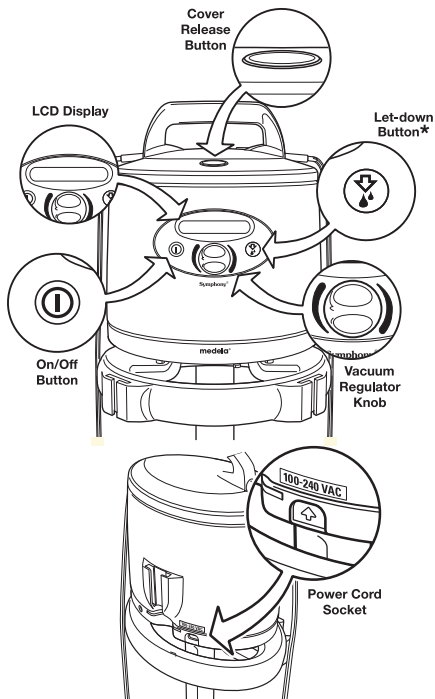

Symphony Kit Diagram

Kit shown is Symphony Double Pumping Kit (67099S)

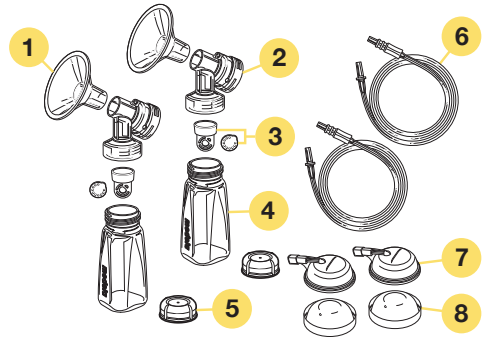

1. PersonalFit™ Breastshield, Standard (24mm).....	87073
2. PersonalFit Breastshield Connector	87071
3. Valve & Membrane	87089
4. Collection Connector.....	8117009
5. Solid Container Lid	8107057
6. Tubing	8007213
7. Membrane Cap	8100769
8. Protective Membrane	8200094
9. Breastfeeding Information Guide	1907200
10. Symphony Instruction Manual.....	1907724
11. Symphony Container Stand	8100552
12. Symphony Vehicle Lighter Adapter.....	67173

Call for pricing

Call Customer Service at 800.435.8316
for ordering information.

Visual & Functionality Checklist

The Symphony® Breastpump Maintenance & Technical Guide is a resource and tool to be used to perform maintenance and troubleshoot issues on the Symphony Breastpump.

A visual and functional check of the Symphony breastpump should be performed for optimal performance on a periodic basis. If maintenance or repairs are needed, this guide will walk you through the steps. If you have any questions, please contact Customer Service at 800.435.8316.

- Cleaning – Use a soft cloth to wipe with warm soapy water, Quick Clean™ Wipes may be used between uses with the same mother. Use Cavicide® to disinfect between different mothers. *(Refer to Cleaning Technical Bulletin on pages 30-31 for detailed instructions.)*
- Cover – Inspect for damage and that cover closes and locks shut. If cover is damaged, please send back to Medela for repairs.
- Housing – Inspect for damage, cracks or if housing is separated. *(Refer to Correct Separated Housing Technical Bulletin on pages 28-29 for detailed instructions.)*
- Rubber Feet – Inspect for damage or missing rubber feet (4 total). If any are missing, contact Medela Customer Service to order Part # 8000596.
- Pump Diaphragms – Inspect for damaged diaphragms. *(Refer to Inspect/Replace Diaphragms Technical Bulletin on pages 12-13 for detailed instructions.)*
- Power Cord – Inspect power cord for damage. *(Refer to Inspect/Replace Power Cord on pages 26-27 for detailed instructions.)*
- If you have a Symphony Plus, check battery status by referring to Battery Care & Maintenance Technical Bulletin on pages 10-11.



Vacuum Check

Performing a vacuum check on your pump ensures your Symphony® is operating correctly for breastpumping mothers. Follow the instructions in the Proper Use of Vacuum Gauge Technical Bulletin on pages 24-25 for detailed instructions. The following values will guide you through gauging your Symphony vacuum levels:

The following values should read:

Stimulation		Expression			
min*	max*	max*	min*	Elevation	OFF
- 41	- 166	- 207	- 41	+ 6600'	
- 47	- 187	- 234	- 47	+ 3300'	
- 50	- 200	- 250	- 50	+ 1600'	
- 53	- 213	- 266	- 53	Sea Level	





*± 20 mmHg

Stimulation mode changes to Expression mode after 2 minutes unless the  button is pushed.

If you experience values outside of the normal limits reference refer to Technical Bulletin – Low or No Suction on pages 14-15.

Recommendations for Replacement

Over the life of the Symphony® it is possible that certain items may have to be replaced. The more preventative maintenance that is conducted on the Symphony, the less parts will have to be replaced. The following are recommended guidelines for when certain parts should be replaced.

Item	Recommendations for Replacement/Repair
	<p>As needed after inspection. <i>(Refer to Low or No Suction Technical Bulletin on pages 14-15 for detailed instructions.)</i></p>
	<p>As needed after inspection or low suction. <i>(Refer to Inspect/Replace Diaphragms on pages 12-13 for detailed instructions.)</i></p>
<p>Motor</p>	<p>6,000 hrs (or as needed)*</p>
<p>Gear Box</p>	<p>6,000 hrs (or as needed)*</p>
	<p>As needed. <i>(Refer to Battery Care & Maintenance Technical Bulletin on pages 10-11 for detailed instructions.)</i></p>
<p>Main Boards</p>	<p>As needed. <i>(If pump does not turn on and after troubleshooting*. Refer to Error Codes Technical Bulletin on pages 8-9.)</i></p>
	<p>If broken or separated. <i>(Refer to Correct Separated Housing Technical Bulletin on pages 28-29 for detailed instructions.)</i></p>

*Must be replaced or repaired at Medela.

Please contact Customer Service at 800.435.8316 for instructions on how to have your pump repaired or replaced.

How to Check Pump Total Running Hours

Checking Pump Total Running Hours



1. Turn the pump on.

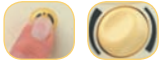

2. Go to service menu by pushing the “On” button again while turning the vacuum control knob.



3. Turn the vacuum control knob until you get “Htot” (hours total). This is the total hours the pump has run throughout its life.

4. Use these hours to check to see if maintenance is required per recommendations on page 6.



Error Codes

There are two ways in which a Symphony® Breastpump will communicate that the unit has an issue. If the Symphony is experiencing an issue, an error code will be displayed on the LCD screen (see fig. 1). Previous problems are recorded in the Menu function under “Err.”. To retrieve a history of errors, hold down the “On” button while turning the vacuum control knob, then continue to move the knob until you reach “Err” (see fig. 2). If you continue to experience issues with your Symphony, please contact Customer Service at 800.435.8316.



LCD Display



LCD Display Messages		
The following describes LCD messages that may be displayed indicating an issue with the unit, the potential causes, and action steps to correct the issue.		
	Potential Issue	Actions
InvalidCard	Program card isn't a Symphony card	Check if correct program card is used (See Technical Bulletin No. 109A)
	Program card is incorrectly inserted	Check that card is positioned correctly (See Technical Bulletin No. 109A)
No card	Program card is damaged and not working	Replace program card (See Technical Bulletin No. 109A)
	Program card isn't inserted	Insert program card (See Technical Bulletin No. 109A)
Battery low	Program card isn't completely inserted	Push card in all the way (See Technical Bulletin No. 109A)
	Battery needs charging soon, will beep every 20 seconds (15 minutes of pumping time remaining from when the indication started)	Be sure power cord is plugged into back of pump (See Technical Bulletin No. 106A)
Battery flat	Battery is completely discharged	Charge the batteries, but you may continue to pump (See Technical Bulletin No. 101A)
Motor overload	Motor is drawing too much current	Send Symphony pump to Medela® service center if this happens repeatedly
Configuration	Software configuration	Replace program card if experiencing error (See Technical Bulletin No. 109A)
Error	Potential fault in electronics of gear control	Send Symphony pump to Medela service center if this happens repeatedly
Power fault	Potential fault in electronics of power supply	Send Symphony pump to Medela service center if this happens repeatedly

Menu Codes

The following are Menu Codes and descriptions indicating historic error activity and steps you can take to address the issue.

Directions on how to read Menu Codes

1. Turn the pump on.
2. Push the “On” button again while turning the vacuum control knob.
3. To see Menu Codes turn the vacuum control knob and refer to the Menu Codes chart listed below.

Menu Codes	Description	Solution
M/F	Motor Fault	<ol style="list-style-type: none"> 1. Unplug and plug back in. 2. Reboot pump. <i>(see below)</i> 3. Replace program card and reboot. 4. Send to Medela, Inc. for repair if this does not solve the issue.
M/O	Motor Overload	<ol style="list-style-type: none"> 1. Return to Medela, Inc. for repair if this happens repeatedly.
C/I	Invalid Card	<ol style="list-style-type: none"> 1. Reboot pump. <i>(see below)</i> 2. Verify proper program card orientation. Correct as needed. 3. Replace program card and reboot. 4. Return to Medela, Inc. for repair if this does not solve the issue.
C/N	No Card	<ol style="list-style-type: none"> 1. Install program card. 2. Verify that card is pushed in all the way. 3. Replace program card and reboot.
B/F	Battery Flat	<ol style="list-style-type: none"> 1. Charge for full 12 hours. 2. Return to Medela, Inc. for repair if this does not solve the issue.
B/L	Battery Low	<ol style="list-style-type: none"> 1. Charge for full 12 hours. Pump will charge during use if plugged in. 2. Return to Medela, Inc. for repair if this does not solve the issue.
P/F	Power Fault	<ol style="list-style-type: none"> 1. Verify pump plugged in properly at both ends. 2. Plug pump into another outlet. 3. Return to Medela, Inc. for repair if this does not solve the issue.
C/F	Configuration	<ol style="list-style-type: none"> 1. Reboot pump. 2. Replace program card and reboot. 3. Return to Medela, Inc. for repair if this does not solve the issue.

Quick Fixes

The following is a list of potential issues and steps you can take to readily address the issue.

Reboot Pump	<ol style="list-style-type: none"> 1. Press the let-down button and hold. 2. While holding the let-down button press the on/off button. 3. Release both buttons when pump reads “please wait”.
Error Messages	<ol style="list-style-type: none"> 1. Turn off pump and restart unit. 2. Reboot pump. 3. Replace program card and reboot pump. <i>(refer to Technical Bulletin No. 109A to replace program card)</i> 4. Send pump to Medela, Inc if this does not solve the issue.
Invalid Card	<ol style="list-style-type: none"> 1. Check program card. <ol style="list-style-type: none"> a. Chip side up. b. Chip end inserted into pump first. 2. Replace program card. Reboot pump with new card. See reboot instructions. 3. Return pump to Medela, Inc. for repair if this does not solve the issue.
No Card	<ol style="list-style-type: none"> 1. If program card is missing: <ol style="list-style-type: none"> a. Install new program card. <i>(refer to Technical Bulletin No. 109A to replace program card)</i> b. Reboot pump with new card. See reboot instructions. 2. If program card is present: <ol style="list-style-type: none"> a. Remove card and reset. b. Send to Medela Inc, for repair if reset does not correct.
No Power	<ol style="list-style-type: none"> 1. Check if the pump is properly connected to the electric supply or that the battery is charged. 2. Inspect power cord and replace if it is damaged. <i>(refer to Technical Bulletin No. 111A to replace power cord)</i> 3. Inspect fuse and replace if needed. <i>(refer to Technical Bulletin No. 106A to replace fuse)</i> 4. Send to Medela Inc, for repair if issue is not resolved.
Check Battery (if present)	<ol style="list-style-type: none"> 1. Check battery connections by removing battery caps and inspecting wires. 2. Refer to Technical Bulletin No. 101A for further Battery Care & Maintenance instructions.

Battery Care & Maintenance

Symphony® Plus needs battery care and maintenance. If you are unable to resolve your Symphony battery issues, please contact Customer Service at 800.435.8316.

Charging Battery

1. The Symphony Plus should be charged:
 - upon receipt of pump (for approximately 12 hours).
 - daily after having run from battery.
 - before battery completely discharges.
 - every two (2) months when pump is not in use. *(The battery is continually charging when the breastpump is plugged into an outlet, even during a pumping session.)*

Battery Status

2. “Battery Low” warning appears on LCD display when the battery is low. The breastpump will beep every 20 seconds. *(The breastpump still has approximately 15 minutes of pumping time left.)* The battery should be re-charged using the above instructions.

3. “Battery Flat” appears when the battery has been depleted. The breastpump will issue a long beep and the pump will switch off. The battery should be re-charged using the above instructions.
4. Check battery connections by removing battery caps and inspecting wires.

Helpful Hints

Extreme temperature, charging rates, and state of charge play a part in the life span of your battery.

To help maintain the life, please do the following:

- completely recharge the battery after each use.
- do not allow the battery to fully drain on a regular basis.
- during use, the Symphony can run on battery for up to one (1) hour.



Battery Check (if battery model)

1. Charge pump for 12 hours.
**NOTE: Display switches from charging to Symphony 2.0 when battery reaches 80% charge. It takes the full 12 hours to get 100% charge.*
2. Turn the pump on.
3. Go to the service menu by pushing the “On” button again while simultaneously turning the vacuum control knob clockwise until S/N is displayed.
4. Release the power button and continue to turn the vacuum control knob until locating “Hres” (resettable hours) then press the let-down button to reset it back to zero.
5. Let the pump run until the batteries are drained and the screen reads “Battery flat.” (The pump turns off automatically after 30 mins and may need to be restarted to fully drain the batteries.)
6. Once the batteries are drained, plug the pump into a wall outlet and go back to “Hres” on the service menu to check how long the pump ran. The time will give an indication of the battery’s condition. A new battery lasts for about 60 minutes of pumping time.



Inspect & Replace Diaphragms

Symphony® diaphragms need to be inspected periodically to ensure proper suction levels. If you experience issues replacing the diaphragms, please contact Customer Service at 800.435.8316.

Tools Required

Flathead Screwdriver

Replacement Diaphragms Kit -
Item #8007199

Cavicide (or similar product)

Soft Cloth

Warning - Please be sure to unplug Symphony prior to troubleshooting.

Directions

Inspect

1-2. Press gently on diaphragm. An undamaged diaphragm will roll along the edge, which does not affect suction. If the rolled edge appears to be torn, replace. If holes or tears appear in diaphragm, suction can be reduced and diaphragm needs to be replaced.

Replace

- 3.** Remove diaphragm screws with flathead screwdriver.
- 4-5.** Gently pry and remove each diaphragm with flathead screwdriver.
- 6-7.** Clean area with soft cloth and Cavicide (or like product) by spraying on cloth before replacing diaphragms.
- 8.** Align new diaphragms with openings.
- 9.** Apply equal pressure downwards to snap diaphragm in place.
- 10.** Install screws with flathead screwdriver. Do not over tighten.



If you experience other issues regarding suction reference Technical Bulletin 103A.

Low or No Suction

In the event that your Symphony® breast-pump is producing low or no suction this technical bulletin will guide you through the steps to troubleshoot your issue. If you continue experiencing issues with low or no suction, please contact Customer Service at 800.435.8316.

Tools Required

Technical Bulletin No. 102A

(Inspecting and Replacing Diaphragms)

Flathead Screwdriver

Symphony Diaphragm Kit -

Item #8007199 *(if needed)*

Symphony Membrane Cap -

Item #8100769 *(if needed)*

Symphony Membrane -

Item #8200094 *(if needed)*

Vacuum Gauge -

Item #1977005 *(if needed)*

Warning – Please be sure to unplug Symphony prior to troubleshooting.

Directions

1. Inspect Symphony Membranes. If membranes do not appear to have a rip or tear move to next step. If membranes do appear to be worn or have a tear, replace prior to next step.
2. Inspect Symphony Diaphragms by following Technical Bulletin 102A. If diaphragms do not appear to have a rip or tear move to next stop.
3. Make sure Symphony lid completely closes before pump is in use.
4. Make sure the hard yellow ends of the tubing fit securely into breastshield connectors.
5. Make sure the yellow triangular end fits into the membrane cap.
6. Make sure yellow valve on breastpump kit is fitted correctly into the breastshield connector.
7. Make sure white membrane is lying flat against yellow valve head.
8. Check Symphony vacuum levels by following Technical Bulletin 110A Proper Use of Vacuum Gauge.

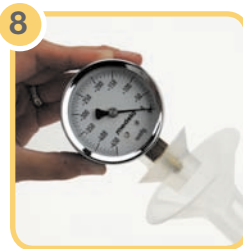

Trolley Repair

In the event that your Symphony® trolley becomes loose, this technical bulletin will guide you through methods to resolve this issue. If you continue to experience issues with your Symphony trolley, please contact Customer Service at 800.435.8316.

Tools Required

3.0mm Allen Wrench

13mm Socket Wrench

Adjustable Wrench

Trolley Repair Kit -

Item #6007116 *(if necessary)*

Directions

- 1-2.** Remove Symphony from trolley by removing four (4) screws with 3.0mm Allen Wrench.
- 3-4.** Turn trolley on side and hold nut by using adjustable wrench. Nut should be Nylok™.
(Nut provided in Repair Kit.)
- 5.** Tighten rod by using 13mm socket wrench while holding nut, which is located on bottom of trolley with adjustable wrench.
(See image #4)
- 6-7.** Place Symphony back on trolley and tighten four (4) screws with 3.0mm Allen wrench.
- 8.** Your Symphony trolley is now tightened and ready for use.

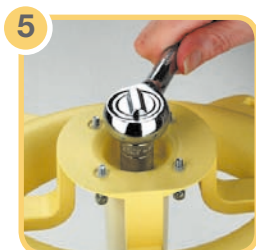

No Power

In the event that your Symphony® breastpump does not have power, this technical bulletin will guide you through methods to resolve the issue. If you continue to experience issues with loss of power, please contact Customer Service at 800.435.8316.

Tools Required

Fuse - Item #9310035

Flathead Screwdriver (*small*)

5. Remove fuse holder from bottom of the Symphony using a small flathead screwdriver and gently turn clock wise.
- 6-7. If the fuse appears shorted, remove shorted fuse. (*Item #9310035*)
- 8-9. Replace with new fuse. (*Item #9310035*)
10. Insert fuse holder (*black round cap*) back into the bottom of the Symphony.

Directions

1. Inspect power cord and replace if damaged. Refer to Technical Bulletin No. 111A - Inspect/Replace Power Cord if power cord needs to be replaced.
2. Make sure pump is plugged into a wall outlet.
3. Make sure short black cord is plugged into back of Symphony.
4. Check power outlet for functionality. Attempt to use in another power outlet.

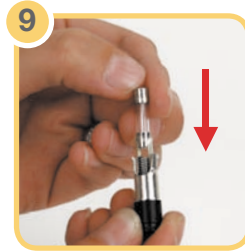
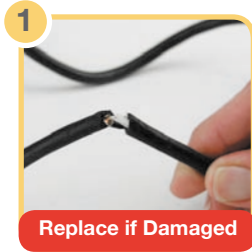

Reseating Cover

In the event that the Symphony® breastpump cover becomes separated or dislodged, this technical bulletin will guide you through the steps to resolve this issue. If you continue to experience issues with the cover, please contact Customer Service at 800.435.8316.

4. Reseat cover over top of the housing. Make sure ridge(s) are not showing.
5. Replace four (4) screws at the bottom of the pump.
6. Symphony cover has been resealed and is ready for use.

Tools Required

Phillips Screwdriver

Warning – Please be sure to unplug the Symphony prior to troubleshooting.

Directions

1. Inspect the pump to locate the housing ridge(s) dislodged outside of cover.
2. Remove four (4) screws at the bottom of the pump with a Phillips Screwdriver.
3. Pull cover straight up (*just enough to clear top of housing*).



Replace and Load Program Card

In the event that your Symphony® displays an “invalid card” or “no card” error, please refer to the following to resolve the issue. If you continue to experience issues with your program card, please contact Customer Service at 800.435.8316.

Tools Required

2.5mm Allen Wrench

(if pump does not have thumb screw)

Symphony Replacement Cards

(if needed)

2.0 Card

English - 67208

French - 67209

Spanish - 67210

Preemie+™ Card



English - 67227

French - 27225

Spanish - 67226

Warning – Please be sure to unplug the Symphony prior to troubleshooting.

Directions

- Loosen thumb screw or 2.5mm allen head screw. Slide cord holder up.
- Remove program card by pulling slowly and gently.
- Gently wipe chip contacts with alcohol wipe or dry towel and re-insert into the Symphony. Hold half circle in hand with micro-chip facing up to insert card.
5. If program card still does not function or is missing, insert a new Symphony program card. Slide cord holder down and tighten screw.
- Plug Symphony into wall outlet and turn Symphony on.
- Press and hold the (let-down)  button.
- While holding (let-down) button press (on/off) button until “Please wait” displays. (This process can take up to 45 seconds.)
- Release buttons. Pump will start running. Press (on/off)  button to turn off.
- Symphony 2.0 or Preemie+™/Standard will be displayed in LCD window.

Symphony is ready for use.

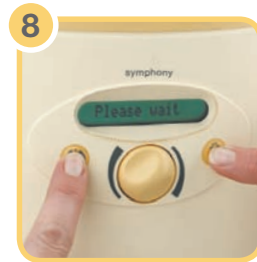
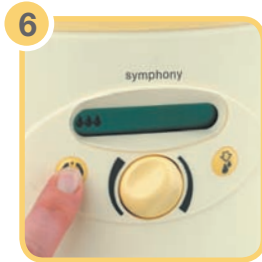

Proper Use of Vacuum Gauge

This technical bulletin will guide you through the steps of checking the vacuum levels of your Symphony® using a vacuum gauge. If you are unable to resolve the issue, please contact Customer Service at 800.435.8316.

Tools Required

Vacuum Gauge -

Item #1977005

Symphony Double Pumping System -

Item #67099

Symphony/Lactina Double Pumping System -

Item #67116

Directions

1. Insert the vacuum gauge into the hole in the rubber stopper.
2. Pull the tab on the rubber stopper to ensure proper fit onto gauge post. The tab should be positioned in the back of the vacuum gauge.
3. Insert the rubber stopper with gauge into breastshield.
4. Ensure a complete seal by firmly pressing on all edges of the stopper.
5. Connect only one Symphony membrane at a time onto diaphragm before you begin testing. Turn on the Symphony to measure the vacuum level. *(Both sides must be tested. Each side should be within 20mmHg or the mom will notice a difference.)*
6. After you have finished checking the vacuum levels, grasp the gauge and stopper tab to remove it.

Symphony Vacuum Settings

Stimulation Phase
120 CPM Vacuum Range 50- 200mmHg
Expression Phase
78-54 CPM (varies) Vacuum Range 50- 250mmHg

Refer to page 3 for extensive values chart for vacuum settings.



Helpful Tips

- Vacuum levels will vary based on weather and elevation. Refer to the pump service instructions for vacuum levels based on elevation.
- Dropping or damaging the vacuum gauge may cause incorrect readings.
- This gauge is intended as a reference tool only, not as a means of accurate measure.

If you need further assistance with troubleshooting low suction with your Symphony, please refer to Technical Bulletin No. 103A.

Inspect & Replace Power Cord

In the event that the Symphony® breastpump power cord becomes damaged, this technical bulletin will guide you through the steps to replace the power cord. If you continue to have problems replacing your power cord, please contact Customer Service at 800.435.8316.

Tools Required

2.5 Allen Wrench

(if pump does not have a thumb screw)

Symphony Power Cord -

Item # - 9280043

Warning – Please be sure to unplug the Symphony prior to troubleshooting.

Directions

1. Inspect power cord for damage., ie
 - 1a. Damaged Cord
 - 1b. Damaged Plug
 - 1c. Bent Prong
 - 1d. Severed Cord
2. Loosen screw and remove the card holder by moving upwards.
3. Remove and discard/recycle bad cord.

4-5. Insert the new cord through the cord holder.

6. Loop the cord around inside of screw post.

7. Place the cord holder back on the pump and tighten the screw.

Symphony power cord has been repaired and is ready for use.



Correct Separated Housing

In the event that the Symphony® Breastpump housing becomes separated or dislodged, this technical bulletin will guide you through the steps to resolve the issue. If you continue to experience issues, please contact Customer Service at 800.435.8316.

Tools Required

Phillips Screwdriver

Warning – Please be sure pump is disconnected from the power cord prior to repairing.

Directions

1. Remove four (4) screws at the bottom of the pump using the Phillips screwdriver.
2. Carefully pull cover straight up.
(Component pieces of pump are attached to cover.)
- 3-4. Snap separated halves back together by carefully aligning tabs.
- 5-6. Replace cover back on pump by aligning internal posts into holes.
7. Reseat cover (making sure to cover housing completely).
8. Replace four (4) bottom screws at the bottom of the pump.
9. Symphony housing has been repaired and is ready for use.



Cleaning

The Symphony® breastpump may be cleaned with Quick Clean™ wipes or a non-abrasive detergent for general cleaning. However, the Symphony should be disinfected between use by different mothers. This technical bulletin guides you through the steps to clean or disinfect your Symphony Breastpump. If you have questions regarding this technical bulletin, please contact Customer Service at 800.435.8316.

Tools Required

Cavicide® 8 fl oz -

Item #3007009

Soft Cloth

Quick Clean™ Wipes -

Item #87056

Warning – Please be sure to unplug Symphony prior to cleaning.

Directions

1. For cleaning in between a mother's own sessions

To clean the pump use a Quick Clean™ wipe to wipe over the breastpump. Optionally, soapy water or a non-abrasive detergent may be used.

2 a-b. For cleaning in between different mothers

To disinfect the pump, we recommend a solution called Cavicide. Spray onto a clean cloth and wipe the breastpump, making sure not to spray or pour liquid directly onto the pump.

3. Do not immerse the pump unit in water; do not spray or pour liquid directly onto the pump.



Terms of Guarantee

The manufacturer may only be held responsible for inadequate safety, reliability and performance of the unit if assembly, additional items, adjustments, alterations and/or repairs have been carried out by persons authorized by the manufacturer and:

- the electrical installation within the room concerned satisfies IEC requirements (in the course of preparation)
- the unit is used as specified in the instructions for use
- accessory kits used on Symphony® Breastpumps are authorized by Medela®, Inc.

Symphony® Preemie+™



*Significantly more milk in less time when premature infants need it most.
Because every drop counts.*

Symphony® Preemie+™

Preemie+ offers two breastpumping pattern programs that have been shown in clinical trials to initiate milk supply in mothers of premature infants and produce significantly more milk in fewer minutes spent pumping.

In addition, Preemie+ has been shown to allow mothers of premature infants to achieve as much milk as mothers of exclusively breastfeeding term infants (530ml) by day 6 of breastpumping.





Medela, Inc., P.O. Box 660, 1101 Corporate Drive, McHenry, IL 60051-0660
Phone: (800) 435-8316 Fax: (815) 363-1246
Email: customer.service@medela.com www.medela.com

Symphony and Medela are registered trademarks and
Premier, Quick Clean and Micro-Steam are trademarks of Medela, Inc.
Cavicide is a registered trademark of Micro Aseptic Products, Inc.
1907555 E 0909 © 2009 Medela, Inc.

Vacuum Check

Performing a vacuum check on your pump ensures your Symphony® is operating correctly for breastpumping mothers. Follow the instructions in the Proper Use of Vacuum Gauge Technical Bulletin on pages 24-25 for detailed instructions. The following values will guide you through gauging your Symphony vacuum levels:

The following values should read:

Stimulation		Expression			
min*	max*	max*	min*	Elevation	OFF
- 41	- 166	- 207	- 41	+ 6600'	
- 47	- 187	- 234	- 47	+ 3300'	
- 50	- 200	- 250	- 50	+ 1600'	
- 53	- 213	- 266	- 53	Sea Level	

*± 20 mmHg

Stimulation mode changes to Expression mode after 2 minutes unless the  button is pushed.

If you experience values outside of the normal limits reference refer to Technical Bulletin – Low or No Suction on pages 14-15.

Proper Use of Vacuum Gauge

This technical bulletin will guide you through the steps of checking the vacuum levels of your Symphony® using a vacuum gauge. If you are unable to resolve the issue, please contact Customer Service at 800.435.8316.

Tools Required

Vacuum Gauge -

Item #1977005

Symphony Double Pumping System -

Item #67099

Symphony/Lactina Double Pumping System -

Item #67116

Directions

1. Insert the vacuum gauge into the hole in the rubber stopper.
2. Pull the tab on the rubber stopper to ensure proper fit onto gauge post. The tab should be positioned in the back of the vacuum gauge.
3. Insert the rubber stopper with gauge into breastshield.
4. Ensure a complete seal by firmly pressing on all edges of the stopper.
5. Connect only one Symphony membrane at a time onto diaphragm before you begin testing. Turn on the Symphony to measure the vacuum level. *(Both sides must be tested. Each side should be within 20mmHg or the mom will notice a difference.)*
6. After you have finished checking the vacuum levels, grasp the gauge and stopper tab to remove it.

Symphony Vacuum Settings

Stimulation Phase
120 CPM Vacuum Range 50- 200mmHg
Expression Phase
78-54 CPM (varies) Vacuum Range 50- 250mmHg

Refer to page 3 for extensive values chart for vacuum settings.



Helpful Tips

- Vacuum levels will vary based on weather and elevation. Refer to the pump service instructions for vacuum levels based on elevation.
- Dropping or damaging the vacuum gauge may cause incorrect readings.
- This gauge is intended as a reference tool only, not as a means of accurate measure.

If you need further assistance with troubleshooting low suction with your Symphony, please refer to Technical Bulletin No. 103A.

Cleaning

The Symphony® breastpump may be cleaned with Quick Clean™ wipes or a non-abrasive detergent for general cleaning. However, the Symphony should be disinfected between use by different mothers. This technical bulletin guides you through the steps to clean or disinfect your Symphony Breastpump. If you have questions regarding this technical bulletin, please contact Customer Service at 800.435.8316.

Tools Required

Cavicide® 8 fl oz -

Item #3007009

Soft Cloth

Quick Clean™ Wipes -

Item #87056

Warning – Please be sure to unplug Symphony prior to cleaning.

Directions

1. For cleaning in between a mother's own sessions

To clean the pump use a Quick Clean™ wipe to wipe over the breastpump. Optionally, soapy water or a non-abrasive detergent may be used.

2 a-b. For cleaning in between different mothers

To disinfect the pump, we recommend a solution called Cavicide. Spray onto a clean cloth and wipe the breastpump, making sure not to spray or pour liquid directly onto the pump.

3. Do not immerse the pump unit in water; do not spray or pour liquid directly onto the pump.

